

NK...U



Air duct heater
with an integrated temperature
control module or a control unit

CONTENTS

Safety requirements	2
Purpose	4
Delivery set	4
Designation key	4
Technical data	5
Unit design and operating logic	12
Mounting and set-up	15
Connection to power mains	16
Control	20
Technical maintenance	20
Storage and transportation regulations	21
Manufacturer's warranty	21
Acceptance certificate	22
Seller information	22
Installation certificate	22
Warranty card	22

The present user's manual consisting of technical details, operating instructions and technical specification contains the information specific to the installation and mounting of the following duct heater models: NK...U(Un).

Hereinafter referred to as „the heater“ or „the unit“ as mentioned in the „Safety requirements“ and „Manufacturer's warranty“ sections as well as in warnings and information blocks.

SAFETY REQUIREMENTS

Read the user's manual carefully prior to installing and operating the unit.

Fulfil the user's manual requirements as well as the provisions of all the applicable local and national construction, electrical and technical norms and standards.

The warnings contained in the user's manual must be considered most seriously since they contain vital personal safety information.

Failure to follow the rules and safety precautions noted in this user's manual may result in an injury or unit damage.

After a careful reading of the manual, keep it for the entire service life of the unit.

While transferring the unit control the user's manual must be turned over to the receiving operator.

Symbol legend:



WARNING!



DO NOT!

UNIT MOUNTING AND OPERATION SAFETY PRECAUTIONS



- Disconnect the unit from power mains prior to any installation operations.



- Unpack the unit with care.



- Do not lay the power cable of the unit in close proximity to heating equipment.



- While installing the unit follow the safety regulations specific to the use of electric tools.

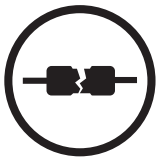

- Do not use damaged equipment or cables when connecting the unit to power mains.



- Do not operate the unit outside the temperature range stated in the user's manual.
- Do not operate the unit in aggressive or explosive environments.



- Do not touch the unit controls with wet hands.
- Do not carry out the installation and maintenance operations with wet hands.

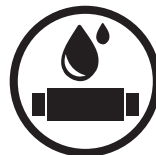

- Do not wash the unit with water.
- Protect the electric parts of the unit against ingress of water.



- Do not allow children to operate the unit.



- Disconnect the unit from power mains prior to any technical maintenance.



- Do not store any explosive or highly flammable substances in close proximity to the unit.



- When the unit generates unusual sounds, odour or emits smoke disconnect it from power supply and contact the Seller.



- Do not open the unit during operation.



- Do not direct the air flow produced by the unit towards open flame or ignition sources.



- Do not block the air duct when the unit is switched on.



- In case of continuous operation of the unit periodically check the security of mounting.

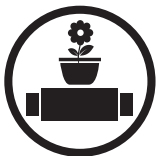

- Do not sit on the unit and avoid placing foreign objects on it.



- Use the unit only for its intended purpose.



DO NOT DISPOSE IN DOMESTIC WASTE.

DO NOT DISPOSE THE PRODUCT WITH UNSORTED MUNICIPAL TRASH.

PURPOSE

The heater is intended to heat up the supply air entering the ventilation system. The built-in temperature control module or the integral control unit ensure that air duct temperature is automatically maintained at the preset level. Being a component unit it may not be commissioned for standalone operation.



THE UNIT MAY NOT BE OPERATED BY CHILDREN OR PERSONS WITH REDUCED PHYSICAL, MENTAL OR SENSORY CAPACITIES, OR LACKING THE APPROPRIATE TRAINING.

THE UNIT MUST BE INSTALLED AND CONNECTED ONLY BY PROPERLY QUALIFIED PERSONNEL AFTER THE APPROPRIATE BRIEFING.

THE CHOICE OF UNIT INSTALLATION LOCATION MUST PREVENT UNAUTHORIZED ACCESS BY UNATTENDED CHILDREN.

The heater is designed for extended periods of continuous operation without disconnection from the power mains. Transported air must not contain any flammable or explosive mixtures, evaporation of chemicals, sticky substances, fibrous materials, coarse dust, soot and oil particles or environments favourable for the formation of hazardous substances (toxic substances, dust, pathogenic germs).

DELIVERY SET

Heater	1 item
User's manual	1 item
Packing box	1 item

DESIGNATION KEY

NK...U(UN) FOR ROUND DUCTS

NK X-X-X X P2

Unit type

NK - duct heater

Connected air duct diameter [mm]

100, 125, 150, 160, 200, 250, 315

Heater power [kW]

Phases

1 - single-phase

3 - three-phase

Control

U - built-in temperature control module or control unit

Un - temperature control module with a external temperature sensor

Power cord with a plug

NK...U(UN) FOR RECTANGULAR DUCTS

NK XxX- X-X U

Unit type

NK - duct heater

Connected air duct width [mm]

400, 500, 600, 700, 800, 900, 1000

Connected air duct height [mm]

200, 250, 300, 350, 400, 500

Heater power [kW]

Phases

3 - three-phase

Built-in control unit

The unit is designed for indoor application at ambient temperature from -30 °C up to +40 °C and relative humidity up to 80 %.

The unit is capable of maintaining the duct temperature in the following range:

from -10 °C to +40 °C (NK...U (Un) units rated from 0.6 kW to 2.4 kW)

from -30 °C to +30 °C (NK...U units rated from 3.0 kW to 54 kW)

The heater is rated as a class I electric appliance.

The heater must be grounded.

Hazardous parts access and water ingress protection standard is IP40.

Allowable deviation from the rated voltage is $\pm 10\%$.

The heater design is constantly improved, so some models may slightly differ from the ones depicted herein.

NK...U(Un) heater with a built-in temperature control module for round ducts (from 0.6 kW to 2.4 kW)	Technical data			
	Minimum air capacity [m ³ /h]	Current [A]	Voltage [V]	Number of electric heating elements x power [kW]
NK 100-0.6-1 U(Un)	60	2.6	230	1 item x 0.6
NK 100-0.8-1 U(Un)	80	3.5	230	1 item x 0.8
NK 100-1.2-1 U(Un)	90	5.2	230	2 items x 0.6
NK 100-1.6-1 U(Un)	120	7.0	230	2 items x 0.8
NK 100-1.8-1 U(Un)	130	7.8	230	3 items x 0.6
NK 125-0.6-1 U(Un)	60	2.6	230	1 item x 0.6
NK 125-0.8-1 U(Un)	80	3.5	230	1 item x 0.8
NK 125-1.2-1 U(Un)	90	5.2	230	2 items x 0.6
NK 125-1.6-1 U(Un)	120	7.0	230	2 items x 0.8
NK 125-2.4-1 U(Un)	150	7.8	230	3 items x 0.8
NK 150-1.2-1 U(Un)	120	5.2	230	1 item x 1.2
NK 150-1.7-1 U(Un)	130	7.4	230	1 item x 1.7
NK 150-2.0-1 U(Un)	140	8.7	230	1 item x 2.0
NK 150-2.4-1 U(Un)	150	10.4	230	2 items x 1.2
NK 160-1.2-1 U(Un)	150	5.2	230	1 item x 1.2
NK 160-1.7-1 U(Un)	160	7.4	230	1 item x 1.7
NK 160-2.0-1 U(Un)	170	8.7	230	1 item x 2.0
NK 160-2.4-1 U(Un)	180	10.4	230	2 items x 1.2
NK 200-1.2-1 U(Un)	150	5.2	230	1 item x 1.2
NK 200-1.7-1 U(Un)	160	7.4	230	1 item x 1.7
NK 200-2.0-1 U(Un)	170	8.7	230	1 item x 2.0
NK 200-2.4-1 U(Un)	180	10.4	230	2 items x 1.2
NK 250-1.2-1 U(Un)	180	5.2	230	1 item x 1.2
NK 250-2.0-1 U(Un)	200	8.7	230	1 item x 2.0
NK 250-2.4-1 U(Un)	265	10.4	230	2 items x 1.2
NK 315-1.2-1 U(Un)	180	5.2	230	1 item x 1.2
NK 315-2.0-1 U(Un)	200	8.7	230	1 item x 2.0
NK 315-2.4-1 U(Un)	265	10.4	230	2 items x 1.2

NK...U heater with a built-in control unit for round ducts (from 3.0 kW to 9.0 kW)	Technical data			
	Minimum air capacity [m ³ /h]	Current [A]	Voltage [V]	Number of electric heating elements x power [kW]
NK 150-3.4-1 U	220	14.7	230	2 items x 1.7
NK 150-3.6-3 U	265	5.2	400	3 items x 1.2
NK 150-5.1-3 U	320	7.4	400	3 items x 1.7
NK 150-6.0-3 U	360	8.7	400	3 items x 2.0
NK 160-3.4-1 U	250	14.8	230	2 items x 1.7
NK 160-3.6-3 U	265	5.2	400	3 items x 1.2
NK 160-5.1-3 U	375	7.4	400	3 items x 1.7
NK 160-6.0-3 U	440	8.7	400	3 items x 2.0
NK 200-3.4-1 U	250	14.8	230	2 items x 1.7
NK 200-3.6-3 U	265	5.2	400	3 items x 1.2
NK 200-5.1-3 U	375	7.4	400	3 items x 1.7
NK 200-6.0-3 U	440	8.7	400	3 items x 2.0
NK 250-3.0-1 U	375	13.0	230	1 item x 3.0
NK 250-3.6-3 U	375	5.2	400	3 items x 1.2
NK 250-6.0-3 U	440	8.7	400	3 items x 2.0
NK 250-9.0-3 U	660	13.0	400	3 items x 3.0
NK 315-3.6-3 U	375	5.2	400	3 items x 1.2
NK 315-6.0-3 U	440	8.7	400	3 items x 2.0
NK 315-9.0-3 U	660	13.0	400	3 items x 3.0

NK...U heater with a built-in control unit for rectangular ducts (from 4.5 kW to 54.0 kW)	Technical data				
	Minimum air capacity [m ³ /h]	Current [A]	Voltage [V]	Power [kW]	Number of electric heating elements x power [kW]
NK 400x200-4.5-3 U	330	6.5	400	4.5	3x1.5
NK 400x200-6.0-3 U	440	8.7	400	6.0	3x2.0
NK 400x200-7.5-3 U	550	10.9	400	7.5	3x2.5
NK 400x200-9.0-3 U	660	13.0	400	9.0	3x3.0
NK 400x200-10.5-3 U	770	15.2	400	10.5	3x3.5
NK 400x200-12.0-3 U	880	17.4	400	12.0	3x4.0
NK 400x200-15.0-3 U	1100	21.7	400	15.0	3x5.0
NK 500x250-6.0-3 U	440	8.7	400	6.0	3x2.0
NK 500x250-7.5-3 U	550	10.9	400	7.5	3x2.5
NK 500x250-9.0-3 U	660	13.0	400	9.0	3x3.0
NK 500x250-10.5-3 U	770	15.2	400	10.5	3x3.5
NK 500x250-12.0-3 U	880	17.4	400	12.0	3x4.0
NK 500x250-15.0-3 U	1100	21.7	400	15.0	3x5.0
NK 500x250-18.0-3 U	1320	26.0	400	18.0	3x6.0
NK 500x250-21.0-3 U	1540	30.0	400	21.0	3x7.0
NK 500x300-6.0-3 U	440	8.7	400	6.0	3x2.5
NK 500x300-7.5-3 U	550	10.9	400	7.5	3x3.0
NK 500x300-9.0-3 U	660	13.0	400	9.0	3x3.5
NK 500x300-10.5-3 U	770	15.2	400	10.5	3x4.0
NK 500x300-12.0-3 U	880	17.4	400	12.0	3x5.0
NK 500x300-15.0-3 U	1100	21.7	400	15.0	3x6.0
NK 500x300-18.0-3 U	1320	26.0	400	18.0	3x7.0
NK 500x300-21.0-3 U	1540	30.0	400	21.0	3x2.5
NK 600x300-9.0-3 U	660	13.0	400	9.0	3x3.0
NK 600x300-12.0-3 U	880	17.4	400	12.0	3x4.0
NK 600x300-15.0-3 U	1100	21.7	400	15.0	3x5.0
NK 600x300-18.0-3 U	1320	26.0	400	18.0	3x6.0
NK 600x300-21.0-3 U	1540	30.0	400	21.0	3x7.0
NK 600x300-24.0-3 U	1760	34.7	400	24.0	3x8.0
NK 600x350-9.0-3 U	660	13.0	400	9.0	3x3.0
NK 600x350-12.0-3 U	880	17.4	400	12.0	3x4.0
NK 600x350-15.0-3 U	1100	21.7	400	15.0	3x5.0
NK 600x350-18.0-3 U	1320	26.0	400	18.0	3x6.0
NK 600x350-21.0-3 U	1540	30.0	400	21.0	3x7.0
NK 600x350-24.0-3 U	1760	34.7	400	24.0	3x8.0
NK 700x400-18.0-3 U	1320	26.0	400	18.0	6x3.0
NK 700x400-27.0-3 U	1980	39.0	400	27.0	9x3.0
NK 700x400-36.0-3 U	2640	52.0	400	36.0	12x3.0
NK 800x500-27.0-3 U	1980	39.0	400	27.0	9x3.0
NK 800x500-36.0-3 U	2640	52.0	400	36.0	12x3.0
NK 800x500-54.0-3 U	3960	78.0	400	54.0	18x3.0
NK 900x500-45.0-3 U	3300	65.0	400	45.0	15x3.0
NK 900x500-54.0-3 U	3960	78.0	400	54.0	18x3.0
NK 1000x500-45.0-3 U	3300	65.0	400	45.0	15x3.0
NK 1000x500-54.0-3 U	3960	78.0	400	54.0	18x3.0

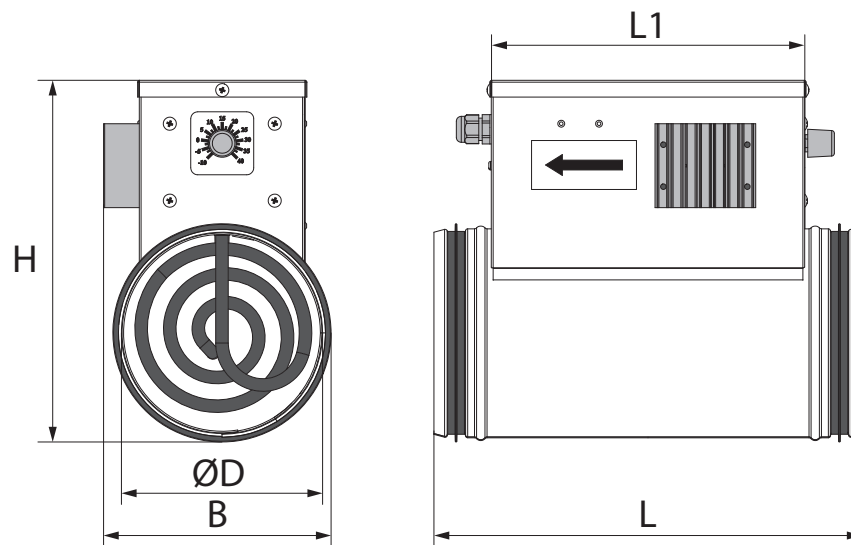
OVERALL DIMENSTIONS OF NK...U(UN) WITH CAPACITY FROM 0.6 KW UP TO 2.4 KW FOR ROUND DUCTS

NK...U(Un) heater with a built-in temperature control module for round ducts (from 0.6 kW to 2.4 kW)	D [mm]	B [mm]	H [mm]	L [mm]	L1 [mm]	Weight [kg]
NK 100-0.6-1 U(Un)	99	94	204	306	227	1.5
NK 100-0.8-1 U(Un)	99	94	204	306	227	1.5
NK 100-1.2-1 U(Un)	99	120	204	370	290	1.6
NK 100-1.6-1 U(Un)	99	120	204	370	290	1.6
NK 100-1.8-1 U(Un)	99	120	204	454	374	1.8
NK 125-0.6-1 U(Un)	124	103	230	306	227	1.6
NK 125-0.8-1 U(Un)	124	103	230	306	227	1.6
NK 125-1.2-1 U(Un)	124	126	230	370	290	1.8
NK 125-1.6-1 U(Un)	124	126	230	370	290	1.8
NK 125-2.4-1 U(Un)	124	126	230	454	374	2
NK 150-1.2-1 U(Un)	149	144	255	306	226	2.1
NK 150-1.7-1 U(Un)	149	144	255	306	226	2.1
NK 150-2.0-1 U(Un)	149	144	255	306	226	2.1
NK 150-2.4-1 U(Un)	149	144	255	370	290	2.6
NK 160-1.2-1 U(Un)	159	154	267	306	226	2.2
NK 160-1.7-1 U(Un)	159	154	267	306	226	2.2
NK 160-2.0-1 U(Un)	159	154	267	306	226	2.2
NK 160-2.4-1 U(Un)	159	154	267	370	290	2.8
NK 200-1.2-1 U(Un)	199	174	302	306	228	2.6
NK 200-1.7-1 U(Un)	199	174	302	306	228	2.6
NK 200-2.0-1 U(Un)	199	174	302	306	228	2.6
NK 200-2.4-1 U(Un)	199	174	302	376	298	3.2
NK 250-1.2-1 U(Un)	249	174	356	306	228	3.3
NK 250-2.0-1 U(Un)	249	174	356	306	228	3.3
NK 250-2.4-1 U(Un)	249	174	356	376	298	3.9
NK 315-1.2-1 U(Un)	313	174	425	306	228	4.1
NK 315-2.0-1 U(Un)	313	174	425	306	228	4.1
NK 315-2.4-1 U(Un)	313	174	425	376	298	5

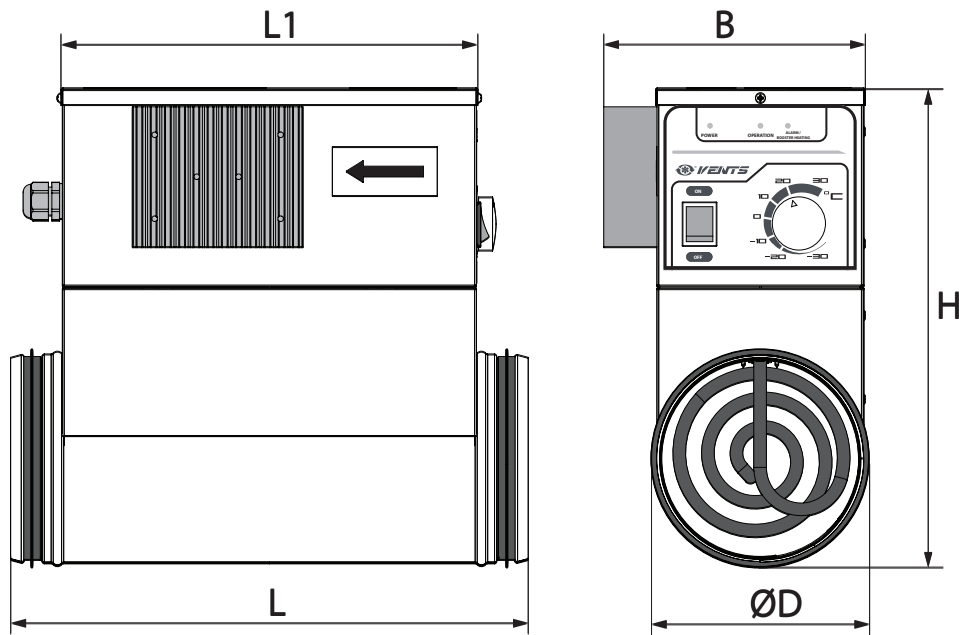
OVERALL DIMENSTIONS OF NK...U WITH CAPACITY FROM 3.0 KW UP TO 9.0 KW FOR ROUND DUCTS

NK...U heater with a built-in control unit for round ducts (from 3.0 kW to 9.0 kW)	D [mm]	B [mm]	H [mm]	L [mm]	L1 [mm]	Weight [kg]
NK 150-3.4-1 U	149	187	340	370	298	4.3
NK 150-3.6-3 U	149	187	340	370	298	4.9
NK 150-5.1-3 U	149	187	340	370	298	4.9
NK 150-6.0-3 U	149	187	340	370	298	4.9
NK 160-3.4-1 U	159	187	350	370	298	4.6
NK 160-3.6-3 U	159	187	350	370	298	5.2
NK 160-5.1-3 U	159	187	350	370	298	5.2
NK 160-6.0-3 U	159	187	350	370	298	5.2
NK 200-3.4-1 U	199	237	389	376	298	5.2
NK 200-3.6-3 U	199	237	389	376	298	5.9
NK 200-5.1-3 U	199	237	389	376	298	5.9
NK 200-6.0-3 U	199	237	389	376	298	5.9
NK 250-3.0-1 U	249	237	446	376	298	5.1
NK 250-3.6-3 U	249	237	446	376	298	6.6
NK 250-6.0-3 U	249	237	446	376	298	6.6
NK 250-9.0-3 U	249	237	446	376	298	6.6
NK 315-3.6-3 U	313	237	514	376	298	7.4
NK 315-6.0-3 U	313	237	514	376	298	7.4
NK 315-9.0-3 U	313	237	514	376	298	7.4

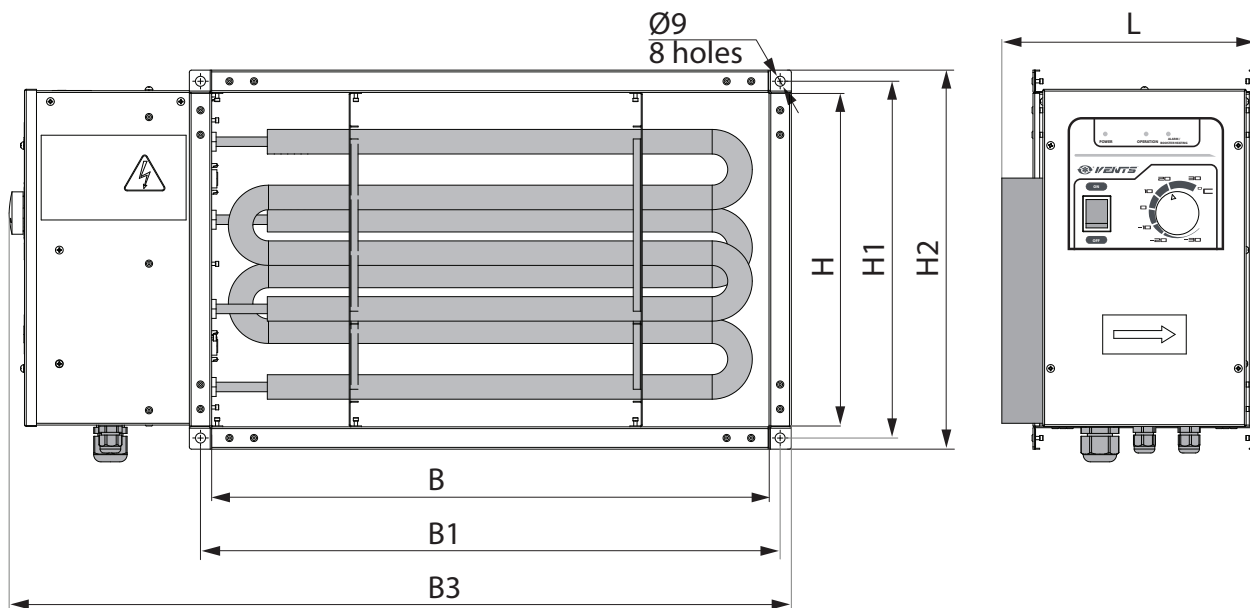
OVERALL DIMENSIONS OF NK...U HEATERS WITH CAPACITY FROM 4.5 KW TO 54 KW FOR RECTANGULAR DUCTS

NK...U heater with a built-in control unit for rectangular ducts (from 4.5 kW to 54.0 kW)	B [mm]	B1 [mm]	B3 [mm]	H [mm]	H1 [mm]	H2 [mm]	L [mm]	Weight [kg]
NK 400x200-4.5-3 U	400	420	611	200	220	240	228	18.24
NK 400x200-6.0-3 U	400	420	611	200	220	240	228	18.24
NK 400x200-7.5-3 U	400	420	611	200	220	240	228	18.24
NK 400x200-9.0-3 U	400	420	665	200	220	240	228	18.52
NK 400x200-10.5-3 U	400	420	665	200	220	240	228	18.52
NK 400x200-12.0-3 U	400	420	665	200	220	240	228	18.52
NK 400x200-15.0-3 U	400	420	665	200	220	240	228	18.52
NK 500x250-6.0-3 U	500	520	702	250	270	290	228	22.4
NK 500x250-7.5-3 U	500	520	702	250	270	290	228	22.4
NK 500x250-9.0-3 U	500	520	702	250	270	290	228	23.0
NK 500x250-10.5-3 U	500	520	702	250	270	290	228	23.0
NK 500x250-12.0-3 U	500	520	702	250	270	290	228	23.0
NK 500x250-15.0-3 U	500	520	702	250	270	290	228	23.1
NK 500x250-18.0-3 U	500	520	702	250	270	290	228	23.1
NK 500x250-21.0-3 U	500	520	702	250	270	290	228	23.1
NK 500x300-6.0-3 U	500	520	702	300	320	340	228	22.9
NK 500x300-7.5-3 U	500	520	702	300	320	340	228	22.9
NK 500x300-9.0-3 U	500	520	702	300	320	340	228	23.5
NK 500x300-10.5-3 U	500	520	702	300	320	340	228	23.5
NK 500x300-12.0-3 U	500	520	702	300	320	340	228	23.5
NK 500x300-15.0-3 U	500	520	702	300	320	340	228	24.0
NK 500x300-18.0-3 U	500	520	702	300	320	340	228	24.0
NK 500x300-21.0-3 U	500	520	702	300	320	340	228	24.0
NK 600x300-9.0-3 U	600	620	802	300	320	340	228	27.0
NK 600x300-12.0-3 U	600	620	802	300	320	340	228	27.0
NK 600x300-15.0-3 U	600	620	802	300	320	340	228	27.5
NK 600x300-18.0-3 U	600	620	802	300	320	340	228	27.5
NK 600x300-21.0-3 U	600	620	802	300	320	340	228	27.5
NK 600x300-24.0-3 U	600	620	802	300	320	340	228	27.5

NK...U heater with a built-in control unit for rectangular ducts (from 4.5 kW to 54.0 kW)	B [mm]	B1 [mm]	B3 [mm]	H [mm]	H1 [mm]	H2 [mm]	L [mm]	Weight [kg]
NK 600x350-9.0-3 U	600	620	802	350	370	390	228	28.2
NK 600x350-12.0-3 U	600	620	802	350	370	390	228	28.2
NK 600x350-15.0-3 U	600	620	802	350	370	390	228	28.5
NK 600x350-18.0-3 U	600	620	802	350	370	390	228	28.5
NK 600x350-21.0-3 U	600	620	802	350	370	390	228	28.5
NK 600x350-24.0-3 U	600	620	802	350	370	390	228	28.5
NK 700x400-18.0-3 U	700	720	924	400	420	440	410	16.8
NK 700x400-27.0-3 U	700	720	924	400	420	440	530	21.0
NK 700x400-36.0-3 U	700	720	924	400	420	440	750	28.0
NK 800x500-27.0-3 U	800	820	1024	500	520	540	410	20.6
NK 800x500-36.0-3 U	800	820	1024	500	520	540	530	25.9
NK 800x500-54.0-3 U	800	820	1024	500	520	540	750	36.1
NK 900x500-45.0-3 U	900	920	1130	500	520	540	750	33.4
NK 900x500-54.0-3 U	900	920	1130	500	520	540	750	38.0
NK 1000x500-45.0-3 U	1000	1020	1230	500	520	540	750	35.5
NK 1000x500-54.0-3 U	1000	1020	1230	500	520	540	750	41.2

DESIGN AND OPERATING LOGIC

NK...U(UN) HEATER WITH A BUILT-IN TEMPERATURE CONTROL MODULE FOR ROUND DUCTS

The heater is equipped with a temperature sensor built into the aluminium tube protecting it against mechanical damage. The sensor is located behind the electric heating elements.

The NK...Un heaters are equipped with an external duct temperature sensor. The sensor is connected by the Manufacturer, sensor cable length – 4 m. The sensor should be installed in the air duct downstream of the electric heating elements. Minimum distance from the electric heating elements to the sensor installation location in the air duct is equal to 2 connected duct diameters.

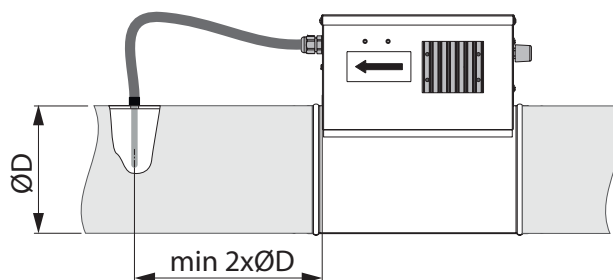

The NK...Un R2 heaters are equipped with a power cord and KE-108 plug, cable length – 2 m. The power cord is connected by the Manufacturer.

The heater casing has a rigidly mounted junction box protected with a removable lid.

The front panel of the junction box has the electronic thermostat control knob with a temperature scale. The rear panel of the junction box has sealed lead-ins for leading the power cable, grounding conductor and the remote temperature sensor cable.

The heater casing encloses electric heating elements.

The casing, the junction box and the heater cover are made of galvanized steel.

The junction box contains the following components:

- fasteners for the heating elements
- electric components for connection to power supply
- ground screw clamp
- manual reset thermoswitch
- electronic thermostat controller circuit board

In the NK 100, 125-0.6 .. 0.8-1 U models the triac is installed on a heat sink inside the junction box. All other models feature external heat sinks to dissipate extra heat.

The heater is also equipped with a manual reset thermoswitch rated to trip at +60 °C. The thermoswitch actuation may be caused by an abnormal temperature increase in the event of the thermostat electronic unit failure.

The wiring diagram is given on the inside of the junction box lid.

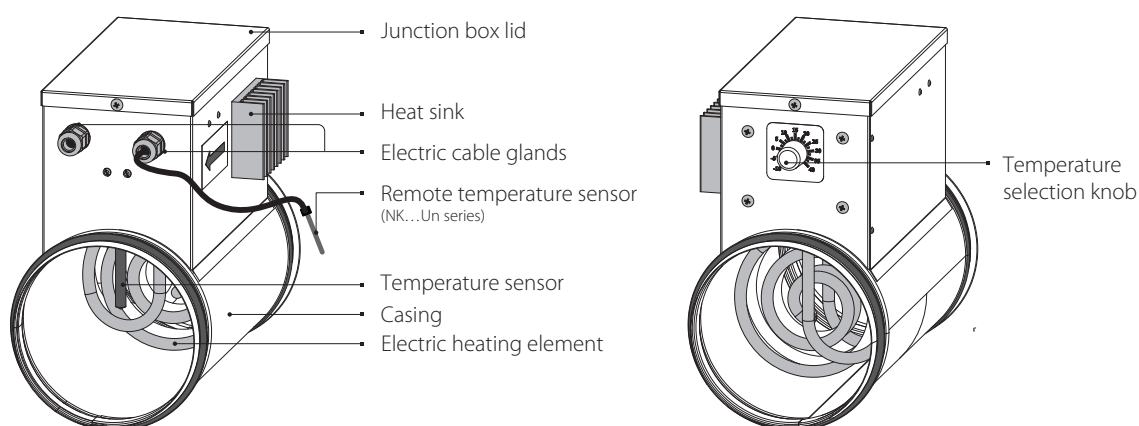

**NK...U WITH CAPACITY FROM 3.0 kW TO 9.0 kW WITH A CONTROL UNIT FOR ROUND DUCTS
AND WITH CAPACITY 4.5 kW TO 54 kW FOR RECTANGULAR DUCTS**

The air duct heaters with capacity from 3.0 kW to 54 kW are equipped with a control unit with a three-phase triac power controller to regulate the output of the electric heating elements.

The units benefit from proportional-integral control used for adjusting the supply air temperature with automatic control function adaptation.

NK...U with a control unit can operate in the following modes:

- Maintaining the heating output proportionally to the 0–10 V external control signal value in the range from 0 to 100 %.
- Maintaining the preset duct temperature according to the temperature sensor feedback.

While switching the external duct temperature sensor mode select one of the temperature sensors below:

- Duct temperature sensor with a sealed end KDT2-M1 (100...400 mm)
- Duct sensor with a mounting flange encased in a rolled tube KDT2-M (100...400 mm)
- Duct sensor with a mounting flange encased in a rolled tube equipped with a terminal box KDT2-M (100...400 mm)

Regulation is carried out via switching-on and switching-off the full load.

The triac power controller of the NK...U heaters effects proportional time control by changing the relation between the load on-time and off-time depending on the pre-programmed heating requirements. For example, if the full load is intermittently on and off in 5 second periods the heater runs at 50 % of its maximum power output. The cycle time (i.e. the total of the load on-time and off-time) is programmed at the factory in the range from 1 to 6 seconds by using the appropriately rated resistance 3.

The load is commutated by means of a triac controller.

The NK...U has two built-in thermal contacts for overheating protection: the automatic reset TK50 with intervention temperature of +50 °C and the manual reset TK90 with intervention temperature of +90 °C. The thermal contacts are connected to the control unit terminals.

The air temperature is set by means of the temperature control knob or an external control device generating a 0-10 V control input signal to increase the duct temperature proportionally in the range from -30 to +30 °C.

The NK...U heaters with integral control units for round ducts consist of a casing with a rigidly mounted junction box which has a removable top lid.

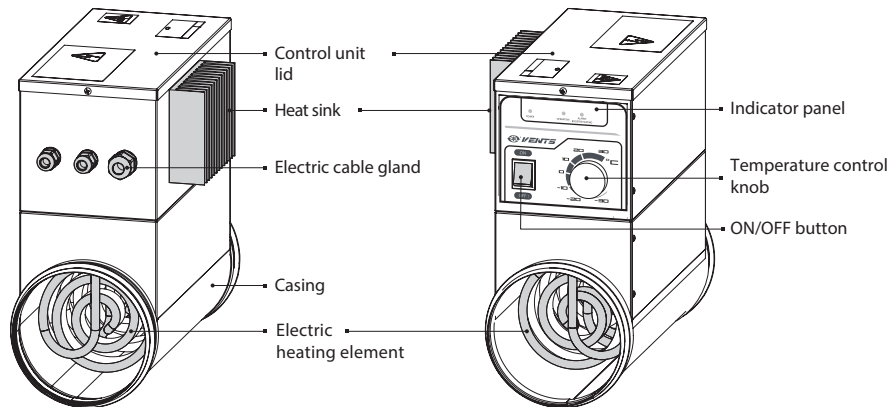

The NK...U heaters with integral control units for rectangular ducts consist of a casing with a rigidly mounted junction box. The junction box has a removable front panel featuring the temperature control knob, the ON/OFF button and the indicator panel.

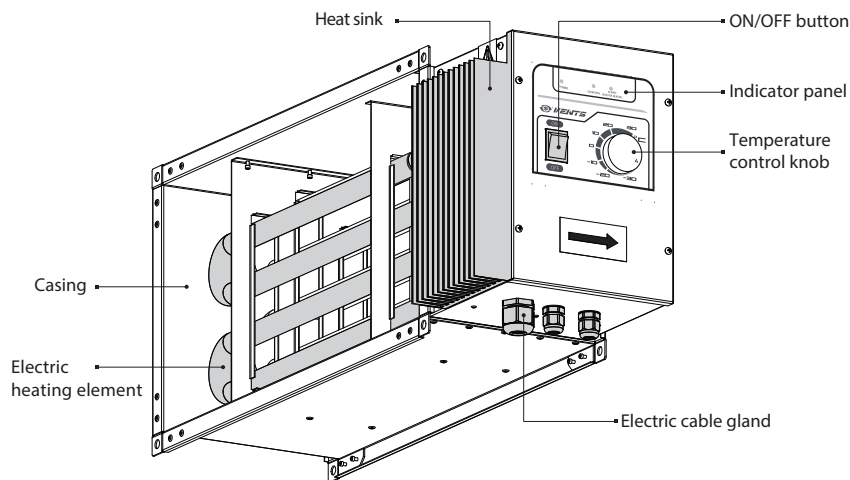

FUNCTIONAL SWITCHES AND INDICATORS

There are three lights on the indicator panel: Power – **AC mains** (green light)
 Status lights – **operation** (yellow light)
 and **Alarm** (red light)

Current state and malfunction indication

AC mains green light	Operation yellow light	Alarm red light	EVENT
-	-	-	No power supply
Operation according to the data from temperature sensor			
ON	BLINKING	-	Temperature boosting: T set > T flow
ON	ON	-	Switching to mode: T set = T flow
Operation in capacity maintenance mode			
ON	BLINKING	-	Blinking frequency is proportional to capacity delivered to electric heating elements
Alarms			
ON	-	ON	TK50 thermal contact actuation
ON	-	BLINKING	No duct pressure switch signal or no enable signal.
ON	-	BLINKING 2-fold periodic	Short circuit of temperature sensor or exceeding sensor operation range (t < -40 °C)
ON	-	BLINKING 3-fold periodic	Freeze protection sensor breakout or exceeding sensor operation range (t > +90 °C)

Controller circuit board functional outputs

- 1 - selection of setpoint adjuster of internal or external temperature controller
- 2 - control mode selection
- 3 - cycle length adjustment resistor (factory-set)
- 4 - triac operation indicator
- 5 - heating cascade 1 indicator
- 6 - heating cascade 2 indicator
- 7 - heating cascade 3 indicator
- 8 - terminal block for temperature sensor connection
- 9 - terminal block for external 0–10 V set-point adjuster
- 10 - terminal block for protection and enabling contacts
- 11 - control circuit board fuse
- 12 - operation indication relay:
 no - alarm or no enable signal
 nc - unit operation

Jumper 1

Set-point adjuster 0–10 V

Internal controller 0–10 V

Jumper 2

Temperature sensor feedback mode using three cascades

Temperature sensor feedback mode using cascade 1

Heating power output maintenance mode using cascade 1

Heating power output maintenance mode using three cascades

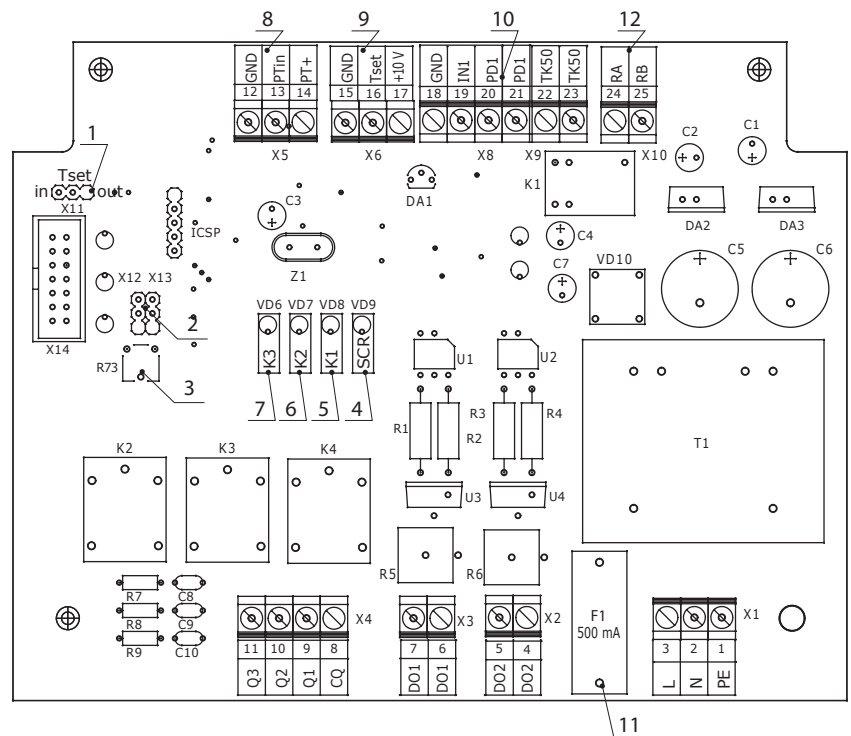

MOUNTING AND SET-UP



READ THIS USER'S MANUAL CAREFULLY PRIOR TO THE UNIT INSTALLATION.



AFTER TRANSPORTATION OR STORAGE UNDER BELOW ZERO TEMPERATURES KEEP THE UNIT IN THE SPECIFIED OPERATION CONDITIONS FOR AT LEAST 4 HOURS BEFORE POWERING UP.

Prior to the heater installation check the heater for the integrity and reliability of the heating element fixation.

The working position of the heater must ensure unimpeded access to the junction box (control unit) and the RESET thermoswitch manual reset button mounted inside the control unit.

The heater must be securely fastened in place. The mounting location must enable quick access to the heater and provide ample space for technical maintenance operations.

The heater must be installed into the ventilation system so that the arrow on the heater casing matches the air flow direction.

The minimum clearance between the heater and other ventilation system components should double the connection size.

No inflammable, explosive or fire-hazardous materials are allowed within 150 mm of the heater casing and within 500 mm of the heater air inlet and outlet. Air ducts and fans must be equipped with a grille or similar protective device preventing free access to the electric heating elements.

Pre-commissioning precautions:

- The unit must be safely grounded in compliance with the „Electrical Installations Regulations“ (i.e. the clamp must be connected to the protective ground wire);
- The minimum air flow through the heater must comply with the value stated in the technical specification. The fan must be installed in the air duct upstream of the heater along the air flow direction to eliminate the possibility of extra heat load on the electric motor. Wherever possible a supply filter should be installed upstream of the heater to reduce contamination.

CONNECTING ROUND AIR DUCTS TO THE HEATER

The heater is designed for inline mounting in the air duct both horizontally and vertically. In a horizontal position the junction box must face upwards. The maximum deviation angle is 90°. The heater junction box may not face downwards.

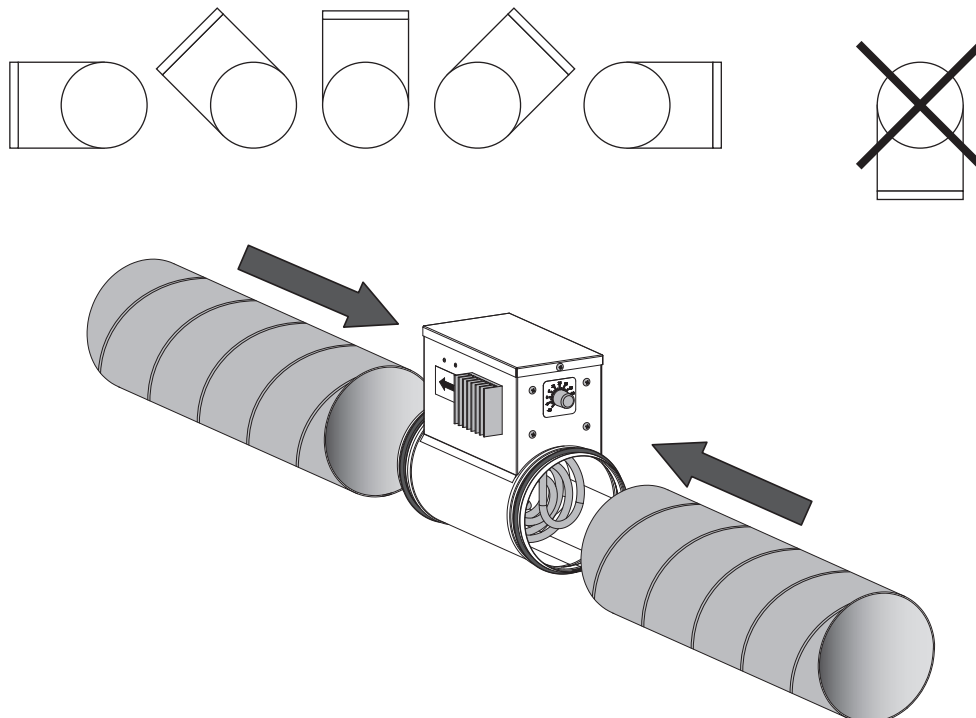

CONNECTING RECTANGULAR AIR DUCTS TO THE HEATER

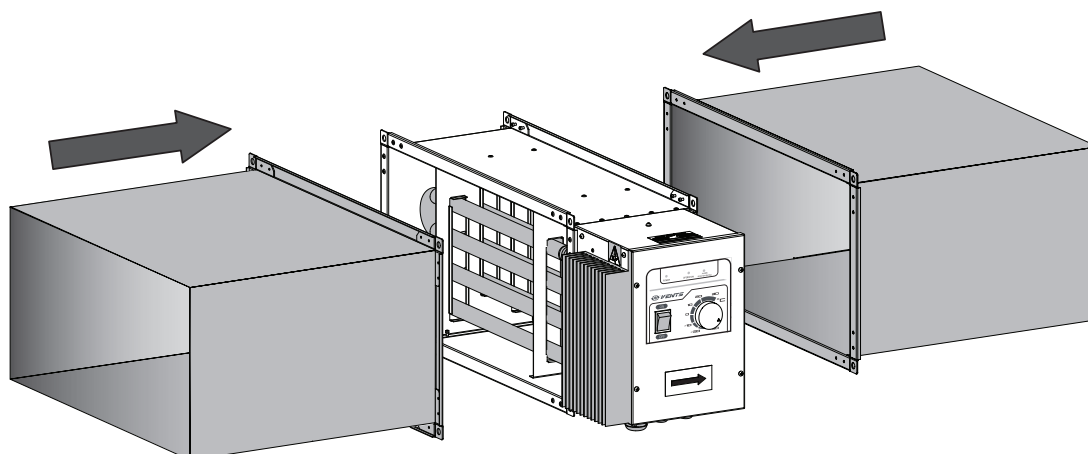

CONNECTION TO POWER MAINS



DISCONNECT THE UNIT FROM POWER SUPPLY PRIOR TO ANY ELECTRIC INSTALLATION OPERATIONS.

THE FAN MUST BE CONNECTED TO POWER MAINS BY A QUALIFIED ELECTRICIAN. THE RATED ELECTRICAL PARAMETERS OF THE UNIT ARE GIVEN ON THE MANUFACTURER'S LABEL.

ANY INTERNAL CONNECTION MODIFICATIONS ARE NOT ALLOWED AND RESULT IN WARRANTY LOSS.

The heater is powered with 230 V / 50 Hz single-phase alternating current or 400 V / 50 Hz three-phase current depending on the particular NK...U(Un) model. The heater connection must be made on the terminal block mounted on a plank inside the junction box or the control unit in accordance with the wiring diagram and terminal designations as shown on the respective schematic.

Route the cables into the unit through sealed lead-ins in the casing sidewall as per the electric hazard class specifications. The external lead-in (230 V / 50 Hz or 400 V / 50 Hz) must be equipped with a circuit breaker built into the stationary wiring to disconnect all the mains phases. The location of the QF external switch must ensure free access for quick shutdown of the heater. The protection trip current must be consistent with the maximum current consumption of the unit. The recommended nominal trip current of the circuit breaker, the cross-section and the number of cores are given in the respective tables.

The heater connections (cables and wires) must be durable, insulated and heat-resistant. The given wire cross sections are for reference only. The cross section selection must account for the maximum permissible wire heating which depends on the wire type, its insulation, length and installation method (i.e. overhead, in pipes or inside walls).

To ensure proper and safe operation the heater should be equipped with an automatic control system capable of comprehensive control and protection – in particular:

- Monitoring the filter condition using the pressure differential sensor feedback.
- Powering off the heater in the event of the supply fan shutdown or air flow velocity drop as well as upon actuation of the built-in overheating protection thermostat.
- Ventilation system shutdown after a 30-second blowing cycle required to cool down the electric heating elements.

The supply voltage must be fed via an automatic circuit breaker with a minimum gap of 3 mm between the open contacts on all poles. The circuit breaker must be integrated into the stationary wiring in accordance with the applicable electrical wiring regulations.

To access the terminal block remove the junction box (control unit) lid.

TERMINAL BLOCK ACCESS

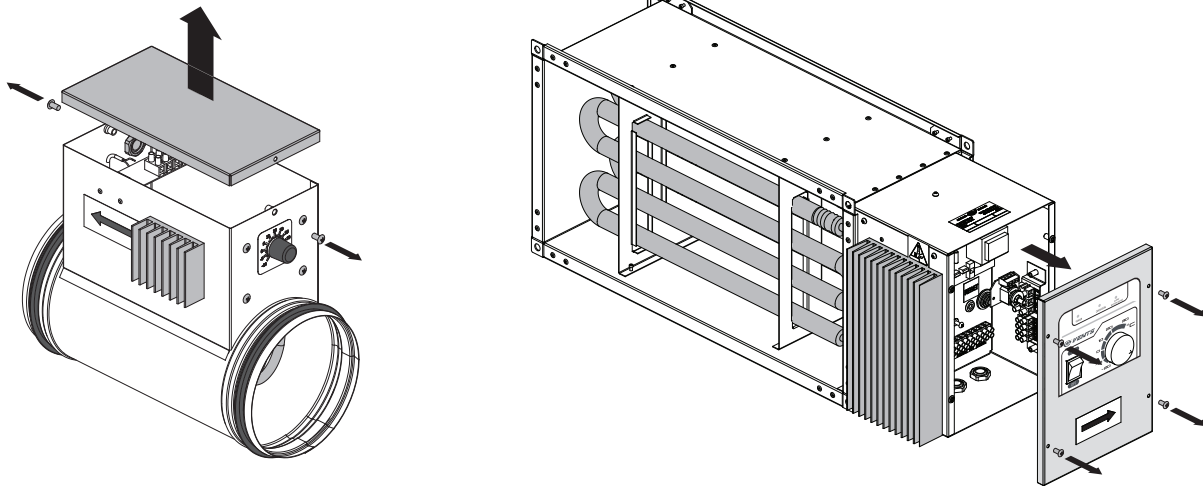

CONNECTION OF NK...U(UN) WITH CAPACITY FROM 0.6 TO 2.4 KW WITH INTEGRATED TEMPERATURE CONTROL MODULE FOR ROUND AIR DUCTS

Automatic circuit breaker trip current selection

NK...U(Un) heater with a built-in temperature control module for round ducts (from 0.6 kW to 2.4 kW)	Voltage [V]	Rated current of the circuit breaker [A]	Number of cores x cross-section [mm ²]
NK 100-0.6-1 U(Un)	230	3.15	3x0.75
NK 100-0.8-1 U(Un)	230	4.0	3x0.75
NK 100-1.2-1 U(Un)	230	6.3	3x2.5
NK 100-1.6-1 U(Un)	230	8.0	3x2.5
NK 100-1.8-1 U(Un)	230	10.0	3x2.5
NK 125-0.6-1 U(Un)	230	3.15	3x0.75
NK 125-0.8-1 U(Un)	230	4.0	3x0.75
NK 125-1.2-1 U(Un)	230	6.3	3x2.5
NK 125-1.6-1 U(Un)	230	8.0	3x2.5
NK 125-2.4-1 U(Un)	230	10.0	3x2.5
NK 150-1.2-1 U(Un)	230	6.3	3x2.5
NK 150-1.7-1 U(Un)	230	8.0	3x2.5
NK 150-2.0-1 U(Un)	230	10.0	3x2.5
NK 150-2.4-1 U(Un)	230	12.5	3x2.5
NK 160-1.2-1 U(Un)	230	6.3	3x2.5
NK 160-1.7-1 U(Un)	230	8.0	3x2.5
NK 160-2.0-1 U(Un)	230	10.0	3x2.5
NK 160-2.4-1 U(Un)	230	12.5	3x2.5
NK 200-1.2-1 U(Un)	230	6.3	3x2.5
NK 200-1.7-1 U(Un)	230	8.0	3x2.5
NK 200-2.0-1 U(Un)	230	10.0	3x2.5
NK 200-2.4-1 U(Un)	230	12.5	3x2.5
NK 250-1.2-1 U(Un)	230	6.3	3x2.5
NK 250-2.0-1 U(Un)	230	10.0	3x2.5
NK 250-2.4-1 U(Un)	230	12.5	3x2.5
NK 315-1.2-1 U(Un)	230	6.3	3x2.5
NK 315-2.0-1 U(Un)	230	10.0	3x2.5
NK 315-2.4-1 U(Un)	230	12.5	3x2.5

Wiring diagrams for NK...U(Un) heaters from 0.6 kW to 2.4 kW

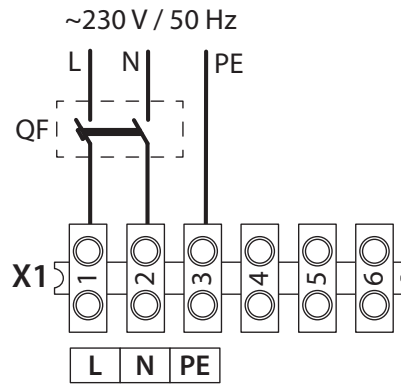
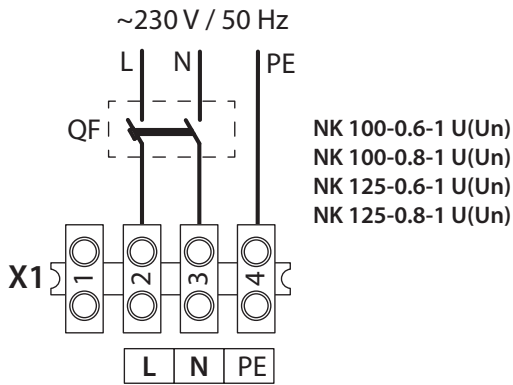

NK 100-1.2-1 U(Un)	NK 160-2.0-1 U(Un)
NK 100-1.6-1 U(Un)	NK 160-2.4-1 U(Un)
NK 100-1.8-1 U(Un)	NK 200-1.2-1 U(Un)
NK 125-1.2-1 U(Un)	NK 200-1.7-1 U(Un)
NK 125-1.6-1 U(Un)	NK 200-2.0-1 U(Un)
NK 125-2.4-1 U(Un)	NK 200-2.4-1 U(Un)
NK 150-1.2-1 U(Un)	NK 250-1.2-1 U(Un)
NK 150-1.7-1 U(Un)	NK 250-2.0-1 U(Un)
NK 150-2.0-1 U(Un)	NK 250-2.4-1 U(Un)
NK 150-2.4-1 U(Un)	NK 315-1.2-1 U(Un)
NK 160-1.2-1 U(Un)	NK 315-2.0-1 U(Un)
NK 160-1.7-1 U(Un)	NK 315-2.4-1 U(Un)

**CONNECTION OF NK...U WITH CAPACITY FROM 3.0 kW TO 9.0 kW
WITH A CONTROL UNIT FOR ROUND DUCTS AND WITH CAPACITY 4.5 kW TO 54 kW FOR RECTANGULAR DUCTS**

Automatic circuit breaker trip current selection

NK...U heater with a built-in control unit for round ducts (from 3.0 kW to 9.0 kW)	Voltage [V]	Rated current of the circuit breaker [A]	Number of cores, cross-section [mm ²]
NK 150-3.4-1 U	230	20	3x2.5
NK 160-3.4-1 U	230	20	3x2.5
NK 200-3.4-1 U	230	20	3x2.5
NK 250-3.0-1 U	230	20	3x2.5
NK 150-3.6-3 U	400	8	5x2.5
NK 160-3.6-3 U	400	8	5x2.5
NK 200-3.6-3 U	400	8	5x2.5
NK 250-3.6-3 U	400	8	5x2.5
NK 315-3.6-3 U	400	8	5x2.5
NK 150-5.1-3 U	400	10	5x2.5
NK 160-5.1-3 U	400	10	5x2.5
NK 200-5.1-3 U	400	10	5x2.5
NK 250-6.0-3 U	400	10	5x2.5
NK 315-6.0-3 U	400	10	5x2.5
NK 250-9.0-3 U	400	16	5x2.5
NK 315-9.0-3 U	400	16	5x2.5

Wiring diagram for single-phase NK...U heaters with a control unit for round ducts from 3.0 kW

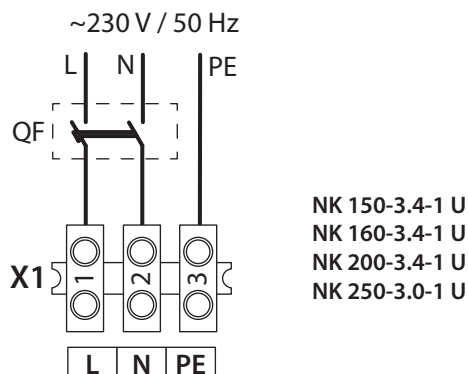

Wiring diagram of NK...U with capacity from 3.0 kW to 9.0 kW with a control unit for round ducts and with capacity 4.5 kW to 54 kW for rectangular ducts (whole model range)

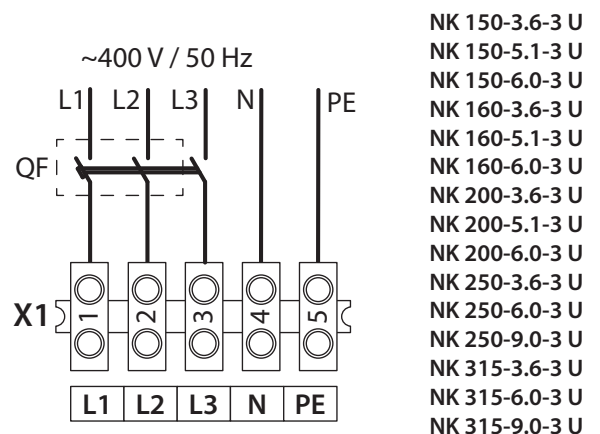

Automatic circuit breaker trip current selection

NK...U heater with a built-in control unit for rectangular ducts (from 4.5 kW to 54.0 kW)	Voltage [V]	Rated current of the circuit breaker [A]	Number of cores, cross-section [mm ²]
NK 400x200-4.5-3 U	400	10	5x2.5
NK 400x200-6.0-3 U	400	10	5x2.5
NK 400x200-7.5-3 U	400	16	5x2.5
NK 400x200-9.0-3 U	400	16	5x2.5
NK 400x200-10.5-3 U	400	20	5x2.5
NK 400x200-12.0-3 U	400	20	5x2.5
NK 400x200-15.0-3 U	400	25	5x2.5
NK 500x250-6.0-3 U	400	10	5x2.5
NK 500x250-7.5-3 U	400	16	5x2.5
NK 500x250-9.0-3 U	400	16	5x2.5
NK 500x250-10.5-3 U	400	20	5x2.5
NK 500x250-12.0-3 U	400	20	5x2.5
NK 500x250-15.0-3 U	400	25	5x2.5
NK 500x250-18.0-3 U	400	31.5	5x4
NK 500x250-21.0-3 U	400	40.0	5x4
NK 500x300-6.0-3 U	400	10	5x2.5
NK 500x300-7.5-3 U	400	16	5x2.5
NK 500x300-9.0-3 U	400	16	5x2.5
NK 500x300-10.5-3 U	400	20	5x2.5
NK 500x300-12.0-3 U	400	20	5x2.5
NK 500x300-15.0-3 U	400	25	5x2.5
NK 500x300-18.0-3 U	400	31.5	5x4
NK 500x300-21.0-3 U	400	40	5x4
NK 600x300-9.0-3 U	400	16	5x2.5
NK 600x300-12.0-3 U	400	20	5x2.5
NK 600x300-15.0-3 U	400	25	5x2.5
NK 600x300-18.0-3 U	400	31.5	5x4
NK 600x300-21.0-3 U	400	40	5x4
NK 600x300-24.0-3 U	400	40	5x4
NK 600x350-9.0-3 U	400	16	5x2.5
NK 600x350-12.0-3 U	400	20	5x2.5
NK 600x350-15.0-3 U	400	25	5x2.5
NK 600x350-18.0-3 U	400	30	5x4
NK 600x350-21.0-3 U	400	40	5x4
NK 600x350-24.0-3 U	400	40	5x4
NK 700x400-18.0-3 U	400	31.5	5x4
NK 700x400-27.0-3 U	400	50	5x6
NK 700x400-36.0-3 U	400	63	5x10
NK 800x500-27.0-3 U	400	50	5x6
NK 800x500-36.0-3 U	400	63	5x10
NK 800x500-54.0-3 U	400	100	5x16
NK 900x500-45.0-3 U	400	80	5x10
NK 900x500-54.0-3 U	400	100	5x16
NK 1000x500-45.0-3 U	400	80	5x10
NK 1000x500-54.0-3 U	400	100	5x16

CONTROL

Connection of NK...U, NK...Un with capacity from 0.6 kW to 2.4 kW with integrated temperature control module for round air ducts

Use the temperature control knob to set the desired temperature in the air duct (thermostat operation threshold). The temperature can be set in the range from -10 °C to +40 °C.

The heater switches on automatically upon the air temperature dropping below the preset thermostat operation threshold.

When the air warms up to the preset level the heater switches off automatically.

NK...U with capacity from 3.0 kW to 54.0 kW with a control unit for round and rectangular air ducts

Complete the electrical connections according to the respective diagram, see page 18.

To use the temperature sensor feedback connect the sensor to the **X2** terminal block.

TE1 [Gnd. PTin. PT+]

- **PT+** – sensor power – „brown“
- **Gnd** – analogue ground contact – „shield“
- **PTin** – sensor signal input – „white“

Jumper 1 (see page 14) sets the heater control method using signals of the external temperature set-point adjuster (the 0–10 V controller) or the feedback from the built-in temperature controller. To use the feedback from an external control device connect it to the **X2** terminal block.

Control [GND. 0–10 V].

- **GND** – analogue ground contact
- **0–10 V** – set-point adjuster input

Protective contact circuit connection.

The „Start“ signal (the activation signal source device) must be connected to the **X2** terminal block: Enable [no and s];

The flow sensing element (the supply filter pressure switch) must be connected to the **X2** terminal block: **PD1** [no and s].

Supply the power voltage to the unit and activate the heater by pressing the ON/OFF button. Then use the controller knob connected to the potentiometer to set the desired temperature in the range from -30 °C to +30 °C.

The NK...U heaters equipped with a control unit have one or several power relays depending on the number of the controlled cascades in use. The relays are connected to the controller circuit board via the TK 90 protective thermal contact at the factory.

External wiring diagram

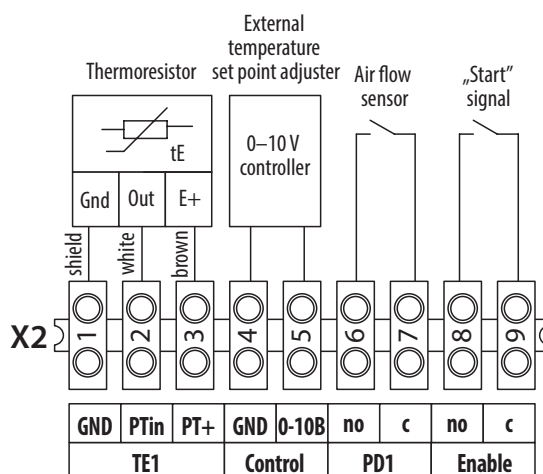

TECHNICAL MAINTENANCE



THE UNIT TECHNICAL MAINTENANCE MUST BE PERFORMED BY ADEQUATELY QUALIFIED AND TRAINED PERSONNEL UPON UNIT DISCONNECTION FROM THE POWER MAINS.

The heater maintenance includes:

Inspection of screw connections as well as rivet and welded joints.

Inspection of tightening of ground screw clamps and electric connections.

Inspection of the wire terminal connections.

Cleaning of the electric heating elements of dust and dirt.

Cleaning with solvents or flammable substances is not allowed.

STORAGE AND TRANSPORTATION REGULATIONS

Store the unit in the manufacturer's original packing box in a dry closed ventilated premise with temperature range from +5 °C to + 40 °C. Storage environment must not contain aggressive vapours and chemical mixtures provoking corrosion, insulation and sealing deformation. The unit can be carried in the original packing by any mode of transport provided proper protection against precipitation and mechanical damage. Use suitable hoist machinery for handling and storage operations to prevent possible damage to the unit. Follow the handling requirements applicable for the particular type of cargo. Avoid sharp blows, scratches or rough handling during loading and unloading. Do not expose the unit to sudden changes in temperature. Such changes can lead to condensation of moisture inside the unit and performance disturbance when the unit is switched on. Prior to the initial power-up after transportation at subzero temperatures allow the unit to warm up at room temperature for at least 4 hours.

MANUFACTURER'S WARRANTY

The manufacturer hereby warrants normal operation of the unit for 24 months after the retail sale date provided the user's observance of the transportation, storage, mounting and operation regulations. Should any malfunctions occur in the course of the unit operation through the Manufacturer's fault during the guaranteed period of operation the user is entitled to elimination of faults by the manufacturer by means of warranty repair at the factory free of charge. The warranty repair shall include work specific to elimination of faults in the unit operation to ensure its intended use by the user within the guaranteed period of operation. The faults are eliminated by means of replacement or repair of the unit components or a specific part of such unit component.

The warranty repair does not include:

- routine technical maintenance
- unit installation / dismantling
- unit setup

To benefit from warranty repair the user must provide the unit, the user's manual with the purchase date stamp and the payment document certifying the purchase.

The unit model must comply with the one stated in the user's manual.

Contact the Seller for warranty service.

The manufacturer's warranty does not apply to the following cases:

- User's failure to submit the unit with the entire delivery package as stated in the user's manual including submission with missing component parts previously dismantled by the user.
- Mismatch of the unit model and the brand name with the information stated on the unit packing and in the user's manual.
- User's failure to ensure timely technical maintenance of the unit.
- External damage to the unit casing (excluding external modifications as required for installation) and internal components caused by the user.
- Redesign or engineering changes to the unit.
- Replacement and use of any assemblies, parts and components not approved by the manufacturer.
- Unit misuse.
- User's violation of the unit installation regulations.
- User's violation of the unit control regulations.
- Unit connection to the power mains with a voltage different from the one stated in the user's manual.
- Unit breakdown due to voltage surges in the power mains.
- Discretionary repair of the unit by the user.
- Unit repair by any persons without the manufacturer's authorization.
- Expiration of the unit warranty period.
- User's violation of the unit transportation regulations.
- User's violation of the unit storage regulations.
- Wrongful actions against the unit committed by third parties.
- Unit breakdown due to circumstances of insuperable force (fire, flood, earthquake, war, hostilities of any kind, blockades).
- Missing seals if provided by the user's manual.
- Failure to submit the user's manual with the unit purchase date stamp.
- Missing payment document certifying the unit purchase.



FOLLOWING THE REGULATIONS STIPULATED HEREIN WILL ENSURE A LONG AND TROUBLE-FREE OPERATION OF THE UNIT.

USERS' WARRANTY CLAIMS SHALL BE SUBJECT TO REVIEW ONLY UPON PRESENTATION OF THE UNIT, THE PAYMENT DOCUMENT AND THE USER'S MANUAL WITH THE PURCHASE DATE STAMP.

ACCEPTANCE CERTIFICATE

Unit Type	Air duct heater with an integrated temperature control module or a control unit
Model	NK _____ U _____
Serial Number	
Manufacture Date	
The product is in compliance with EU norms and standards on low voltage guidelines and electromagnetic compatibility. We hereby declare that the product complies with the protection requirements of Electromagnetic Council Directive 2014/30/EU, Low Voltage Directive 2014/35/EU and CE-marking Directive 93/68/EEC on the approximation of the laws of the Member States relating to electromagnetic compatibility.	
Quality Inspector's Stamp	

SELLER INFORMATION

Seller	
Address	
Phone Number	
E-mail	
Purchase Date	
This is to certify acceptance of the complete unit delivery with the user's manual. The warranty terms are acknowledged and accepted.	
Customer's Signature	

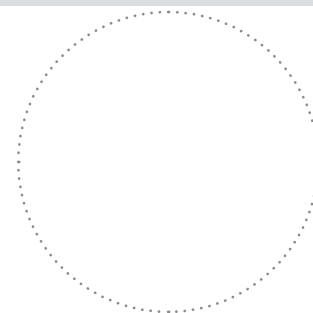

Seller's Stamp

INSTALLATION CERTIFICATE

The unit has been connected to power mains pursuant to the requirements stated in the present user's manual.	
Company Name	
Address	
Phone Number	
Installation Technician's Full Name	
Installation Date:	Signature:
The unit has been installed in accordance with the provisions of all the applicable local and national construction, electrical and technical codes and standards. The unit operates normally as intended by the manufacturer.	
Signature:	

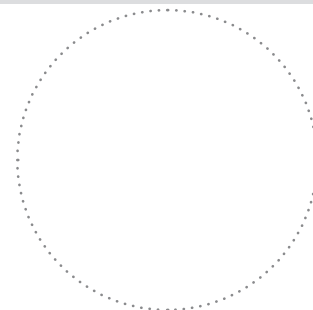

Installation Company Stamp

WARRANTY CARD

Unit Type	Air duct heater with an integrated temperature control module or a control unit
Model	NK _____ U _____
Serial Number	
Manufacture Date	
Purchase Date	
Warranty Period	
Seller	

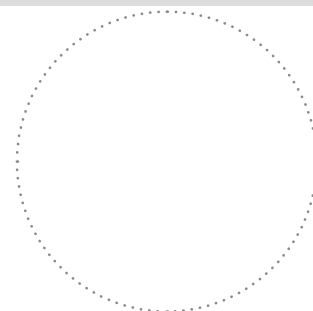

Seller's Stamp

