

Series  
**VENTS VUT/VUE VB EC**



Air handling units in heat- and sound-insulated casing.  
Air flow up to **690 m<sup>3</sup>/h**.  
Heat recovery efficiency up to **93 %**

**Description**

The air-handling units are the fully featured ventilation units with heat recovery for air filtration, fresh air supply and stale air extraction.

**Casing**

Made of high-quality polymer coated steel, internally filled with mineral wool layer for heat and sound insulation.

**Filter**

Supply and exhaust air flows are purified through panel filters with filtering class G4 and F7, respectively. Filters with G4 filtering class are used for supply and exhaust air purification in the **VUT/VUE 250 VB EC** units. F7 filter is available as an option for supply air filtration.

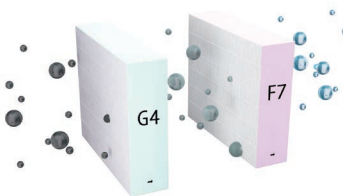

**Fans**

The units are equipped with high-efficient EC motors with an external rotor and a centrifugal impeller with backward curved blades.

**Heat exchanger**

The **VUT V(B) EC** units are equipped with a counter-flow polystyrene heat exchanger.

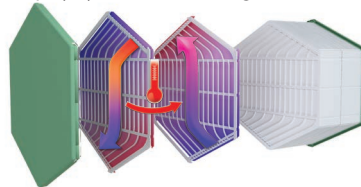

The **VUE V(B) EC** units are equipped with a counter-flow enthalpy heat exchanger.

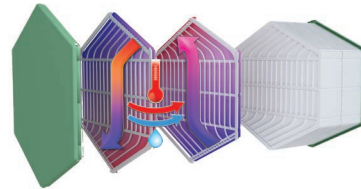

**Bypass**

The **VUT/VUE VB EC** units are equipped with a bypass for summer cooling.

**Automation**

The **VUT/VUE V(B) EC A21** units are equipped with a built-in automation system. The A21 controller allows integrating the unit into the Smart Home system or BMS (Building Management Systems). To control the unit via Wi-Fi, download the VENTS Home mobile app.

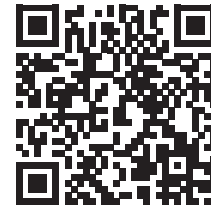

The **VUT/VUE V(B) EC A14** units have an integrated control system with a wall-mounted control panel A14 with a LED indication.

**Freeze protection**

In the **VUT/VUE 160/350/550 VB EC A21** units it is possible to connect a preheater to protect the unit from freezing.

The **VUT 250 VBE EC A21** unit is equipped with a built-in preheater for frost protection.

**Mounting**

The units are designed for wall or floor mounting. Access for maintenance of units and filters is possible from the right and left sides.

**Overall dimensions**

Model	Dimensions [mm]			
	Ø D	B	H	L
VUT/VUE 160 V EC	125	330	550	600
VUT/VUE 160 V1 EC	125	370	590	640
VUT/VUE 160 VB EC	125	330	580	600
VUT/VUE 160 V1B EC	125	370	620	640
VUT/VUE 250 VB EC L/R	160	560	970	560
VUT/VUE 350 VB EC	160	583	675	730
VUT/VUE 350 V1B EC	160	470	675	730
VUT/VUE 550 VB EC	200	720	675	823

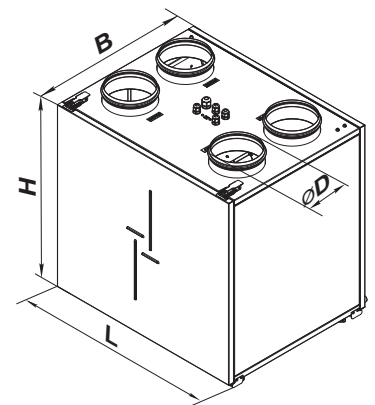





**Designation key**

Series	Rated air flow [m <sup>3</sup> /h]	Installation features	Casing design	Bypass	Motor type	Service side*	Control
<b>VUT:</b> ventilation with heat recovery <b>VUE:</b> ventilation with energy recovery	160, 250, 350, 550	<b>V:</b> vertical	- by default <b>1:</b> casing modification	_ : without bypass <b>B:</b> with bypass	<b>EC:</b> synchronous electronically commutated motor	<b>L:</b> left <b>R:</b> right	<b>A14</b> <b>A21</b>

\* Only for VUT 250 VB EC L/R

**Control and automation**

Functions	A21	A14
Wired remote control panel	Option (A22) 	A14 
Control via a wired remote LCD control panel	Option (A25) 	-
Wireless remote control panel	Option (A22 Wi-Fi) 	-
BMS	RS-485 Wi-Fi Ethernet MODBUS (RTU, TCP)	-
Vents Cloud Server service	+	-
Control via Wi-Fi using a mobile application	+	-
Freeze protection	+	+
Bypass	Auto + manual	Manual
Week-scheduled operation	+	-
Filter replacement indication	By the filter timer	By the filter timer
	According to filter clogging differential pressure switch readings (only for VUT/VUE 550 VB EC A21)	
Alarm indication	+	+
Speed selection	+	+
Timer	+	-
RH% sensor	Option	Option
CO <sub>2</sub> sensor	Option	Option
VOC sensor	Option	Option
PM2.5 sensor	Option	Option
Boost mode	+	-
Fireplace mode	+	-
Preheater connection	Option (built-in preheater in VUT 250 VBE EC units)	-
Reheater connection	Option	-
Cooler connection	Option	-
Fire alarm sensor	Option	Option
Minimum supply air temperature control	+	-

**Unit design**

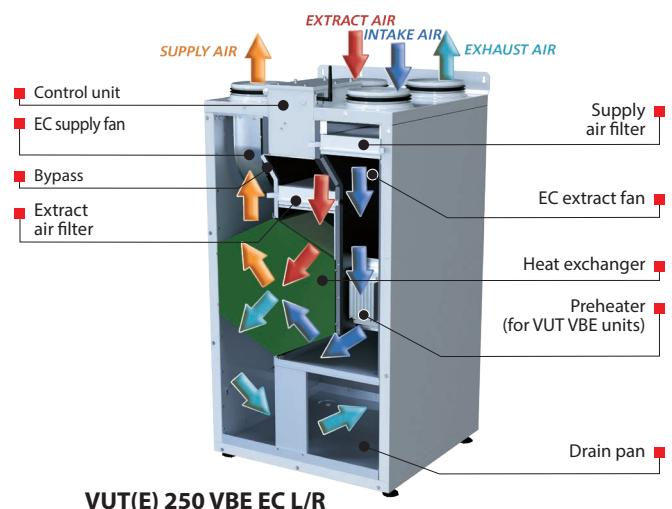
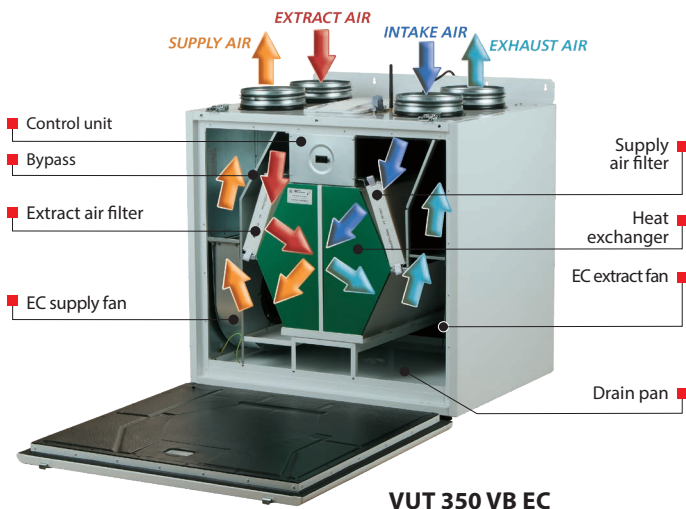

## Technical data

	VUT 160 V EC	VUE 160 V EC	VUT 160 VB EC	VUE 160 VB EC	VUT 160 V1 EC	VUE 160 V1 EC	VUT 160 V1B EC	VUE 160 V1B EC
Unit voltage [V/50 (60) Hz]					1~230			
Maximum power [W]					57			
Maximum current [A]					0.5			
Maximum air flow [m <sup>3</sup> /h]					200			
RPM [min <sup>-1</sup> ]					3770			
Sound pressure level at 3 m distance [dBA]	24					22		
Transported air temperature [°C]					-25...+40			
Casing material	painted steel							
Insulation	20 mm mineral wool				40 mm mineral wool			
Extract filter					G4			
Supply filter					F7 (G4 – option)			
Connected air duct diameter [mm]	Ø125							
Weight [kg]	34		36		42		44	
Heat recovery efficiency [%]	85–93	76–92	85–93	76–92	85–93	76–92	85–93	76–92
Heat exchanger type	counter-flow							
Heat exchanger material	polystyrene	enthalpy	polystyrene	enthalpy	polystyrene	enthalpy	polystyrene	enthalpy
Energy efficiency class for A14, A21	A+	A	A+	A	A+	A	A+	A

## VENTS VUT/VUE V(B) EC

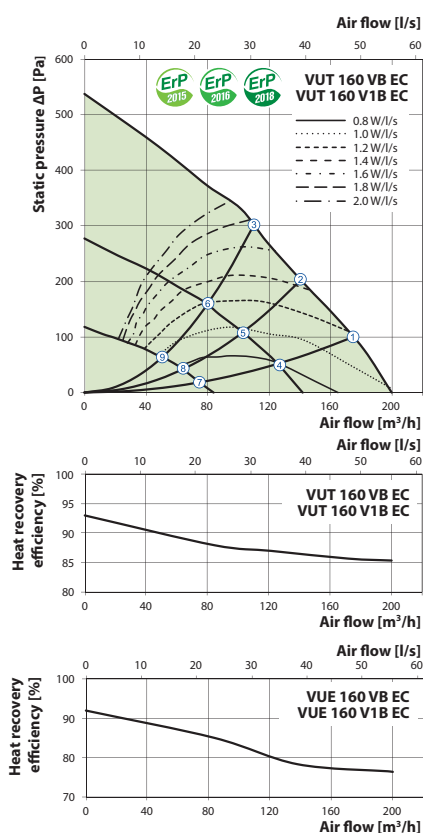

### VUT 160 V EC, VUE 160 V EC, VUT 160 VB EC, VUE 160 VB EC

A-weighted sound power level	Gen. dBA	Octave frequency band [Hz]								LpA, 3 m dBA	LpA, 1 m dBA	
		63	125	250	500	1000	2000	4000	8000			
L <sub>WA</sub> to supply air inlet	dBA	52	28	46	49	41	35	33	36	29		
L <sub>WA</sub> to supply air outlet	dBA	60	32	52	58	47	37	36	41	35		
L <sub>WA</sub> to exhaust air inlet	dBA	51	27	45	49	41	36	32	35	29		
L <sub>WA</sub> to exhaust air outlet	dBA	60	31	50	59	48	36	36	41	32		
L <sub>WA</sub> to environment	dBA	45	25	41	42	34	31	28	27	22	24	34

### VUT 160 V1 EC, VUE 160 V1 EC, VUT 160 V1B EC, VUE 160 V1B EC

A-weighted sound power level	Gen. dBA	Octave frequency band [Hz]							LpA, 3 m dBA	LpA, 1 m dBA		
		63	125	250	500	1000	2000	4000			8000	
L <sub>WA</sub> to supply air inlet	dBA	52	28	46	49	41	35	33	36	29		
L <sub>WA</sub> to supply air outlet	dBA	60	32	52	58	47	37	36	41	35		
L <sub>WA</sub> to exhaust air inlet	dBA	51	27	45	49	41	36	32	35	29		
L <sub>WA</sub> to exhaust air outlet	dBA	60	31	50	59	48	36	36	41	32		
L <sub>WA</sub> to environment	dBA	43	23	39	39	33	29	25	25	20	22	32

### Calculation of air temperature at heat exchanger outlet:

$$t = t_{\text{outd}} + k_{\text{hr}} * (t_{\text{extr}} - t_{\text{outd}}) / 100,$$

where

$t_{\text{outd}}$  is outdoor air temperature [°C]

$t_{\text{extr}}$  is extract air temperature [°C]

$k_{\text{hr}}$  is heat exchanger efficiency (according to the diagram) [%]

**Technical data**

	VUT 250 VB EC L/R	VUE 250 VB EC L/R	VUT 250 VBE EC L/R	VUE 250 VBE EC L/R
Unit voltage [V/50 (60) Hz]	1~230			
Maximum power [W]	180			
Maximum current [A]	1.37			
Electric heater power [W]	-			1400
Electric heater current [A]	-			6.09
Maximum unit power with an electric heater [W]	180			1580
Maximum unit current (with an electric heater) [A]	1.37			7.46
Maximum air flow [m³/h]	390			
RPM [min <sup>-1</sup> ]	2600			
Sound pressure level at 3 m distance [dBA]	35			
Transported air temperature [°C]	-25...+40			
Casing material	painted steel			
Insulation	30 mm mineral wool			
Extract filter	G4			
Supply filter	G4 (F7 – option)			
Connected air duct diameter [mm]	Ø160			
Weight [kg]	66			
Heat recovery efficiency [%]	88–95	78–90	88–95	78–90
Heat exchanger type	counter-flow			
Heat exchanger material	polystyrene	enthalpy	polystyrene	enthalpy
Energy efficiency class for A14, A21	A+	A	A+	A

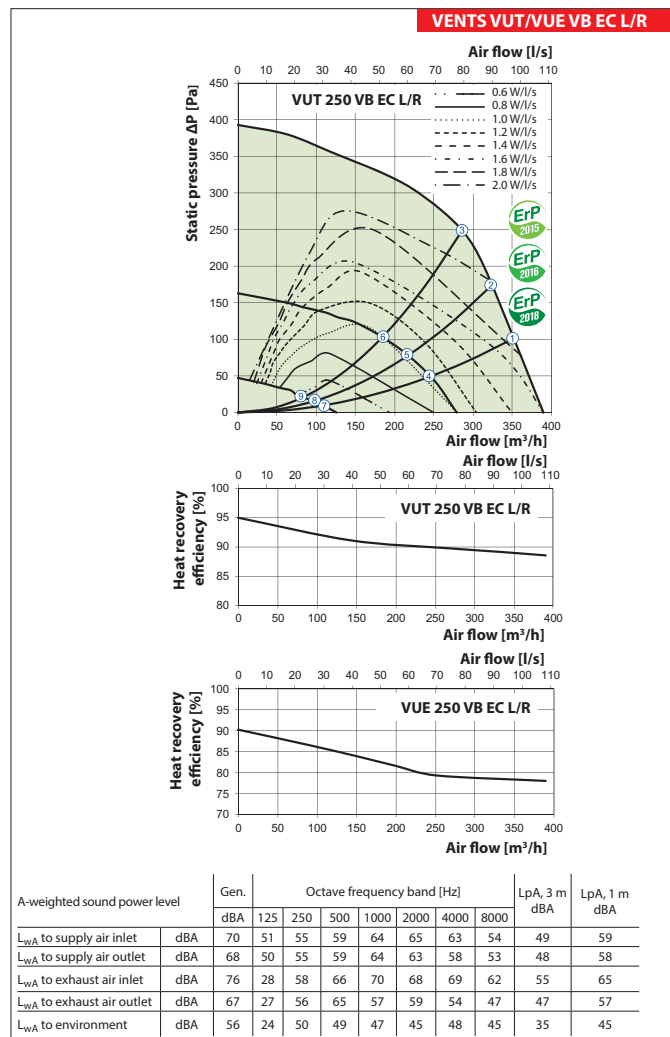



# AIR HANDLING UNITS WITH HEAT RECOVERY

## Technical data

	VUT 350 V1B EC	VUE 350 V1B EC	VUT 350 VB EC	VUE 350 VB EC
Unit voltage [V/50 (60) Hz]	1~230		1~230	
Maximum power [W]	169		178	
Maximum current [A]	1.3		1.4	
Maximum air flow [m³/h]	420		450	
RPM [min <sup>-1</sup> ]	3200		3200	
Sound pressure level at 3 m distance [dBA]	28		28	
Transported air temperature [°C]	-25...+40		-25...+40	
Casing material	painted steel		painted steel	
Insulation	40 mm mineral wool		40 mm mineral wool	
Extract filter	G4		G4	
Supply filter	F7 (G4 – option)		F7 (G4 – option)	
Connected air duct diameter [mm]	Ø160		Ø160	
Weight [kg]	57		64	
Heat recovery efficiency [%]	85–92	74–91	85–92	73–91
Heat exchanger type	counter-flow		counter-flow	
Heat exchanger material	polystyrene	enthalpy	polystyrene	enthalpy
Energy efficiency class for A14, A21	A+	A	A+	A

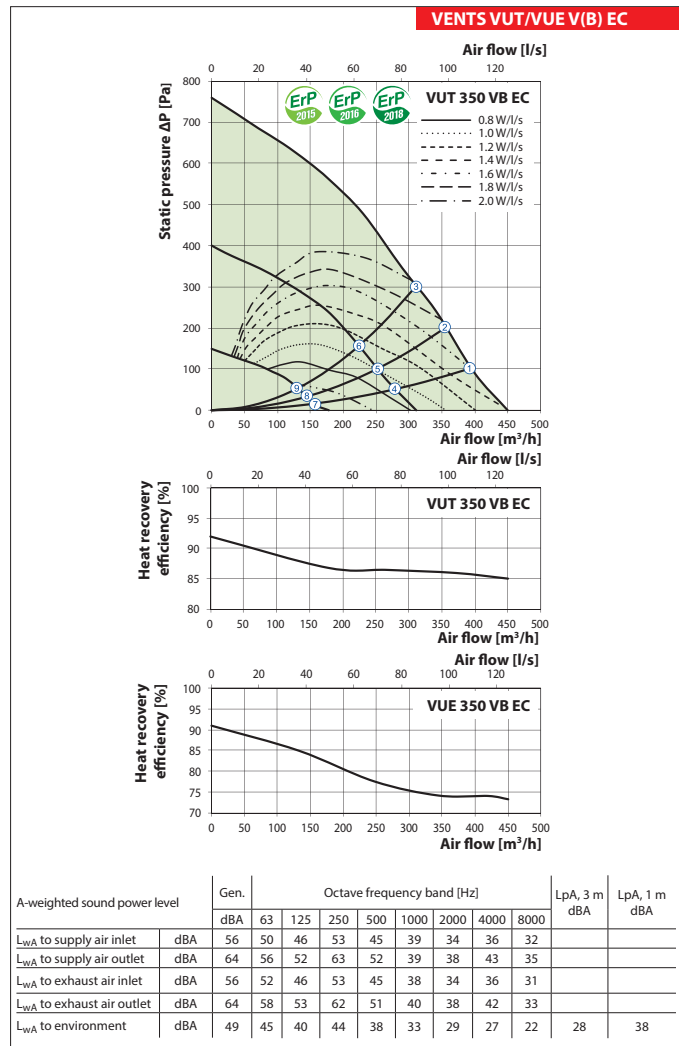
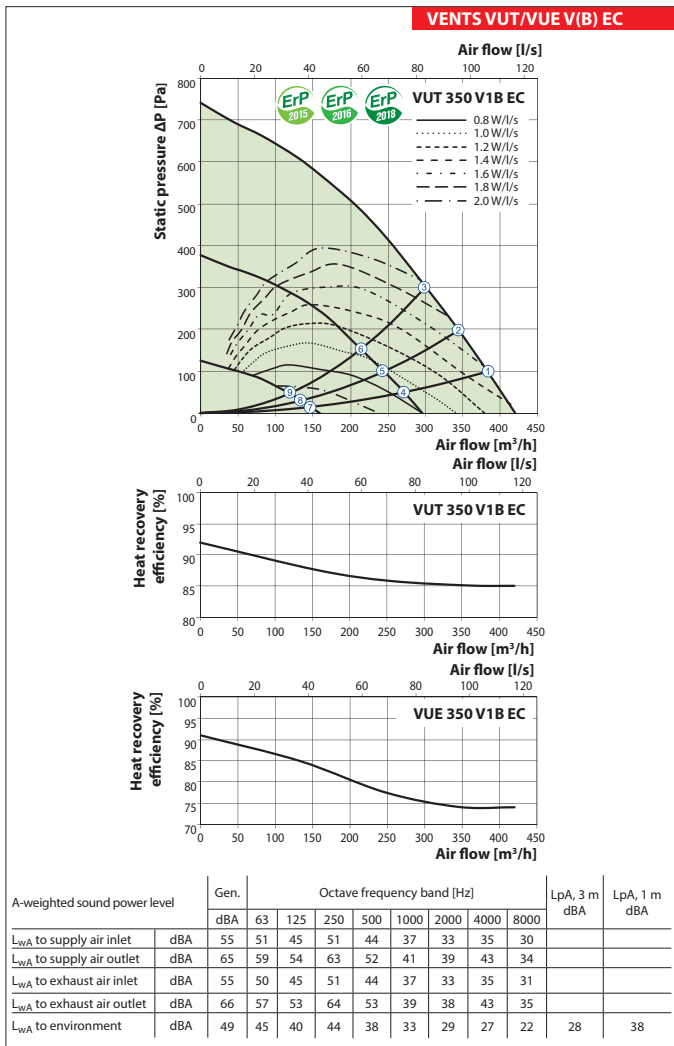

**Technical data**

	VUT 550 VB EC	VUE 550 VB EC
Unit voltage [V/50 (60) Hz]	1~230	
Maximum power [W]	337	
Maximum current [A]	2.4	
Maximum air flow [m³/h]	690	
RPM [min <sup>-1</sup> ]	2860	
Sound pressure level at 3 m distance [dBA]	26	
Transported air temperature [°C]	-25...+40	
Casing material	painted steel	
Insulation	40 mm mineral wool	
Extract filter	G4	
Supply filter	F7 (G4 – option)	
Connected air duct diameter [mm]	Ø200	
Weight [kg]	82	
Heat recovery efficiency [%]	84–92	73–91
Heat exchanger type	counter-flow	
Heat exchanger material	polystyrene	enthalpy
Energy efficiency class for A14, A21	A+	A

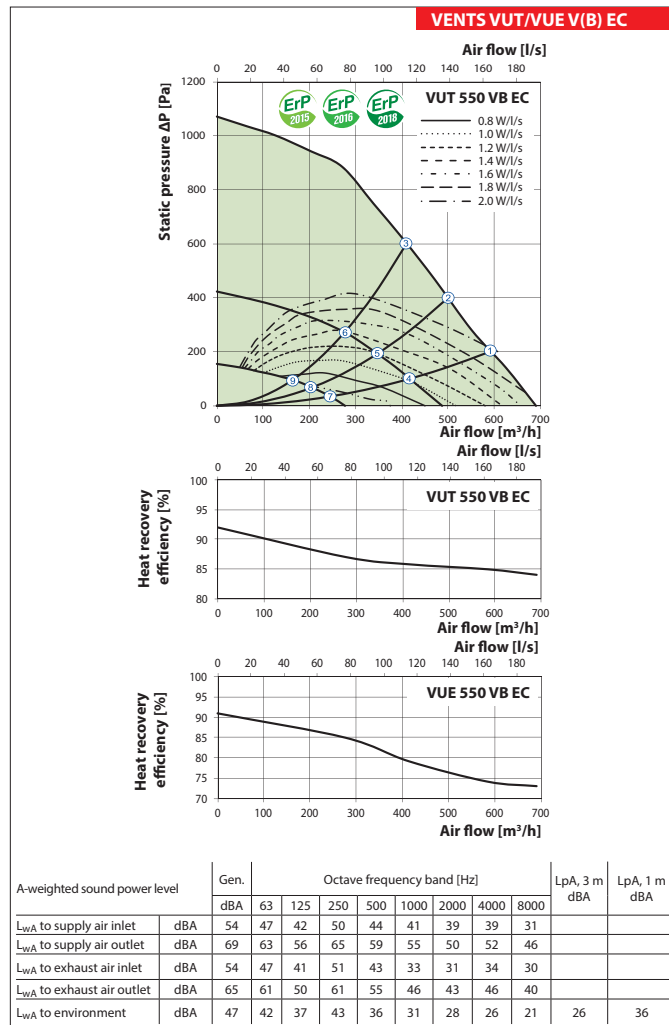

Technical data

VUT 350 VB EC				VUT 550 VB EC			
Outlet spigot configuration	Air flow [l/s]	Specific power input [W/l/s]	Heat exchange efficiency [%]	Outlet spigot configuration	Air flow [l/s]	Specific power input [W/l/s]	Heat exchange efficiency [%]
Kitchen + 1 additional room with high level of humidity	21	0.71	88	Kitchen + 1 additional room with high level of humidity	21	0.71	87
Kitchen + 2 additional rooms with high levels of humidity	29	0.64	88	Kitchen + 2 additional rooms with high levels of humidity	29	0.63	88
Kitchen + 3 additional rooms with high levels of humidity	37	0.68	87	Kitchen + 3 additional rooms with high levels of humidity	37	0.63	88
Kitchen + 4 additional rooms with high levels of humidity	45	0.76	86	Kitchen + 4 additional rooms with high levels of humidity	45	0.72	88
Kitchen + 5 additional rooms with high levels of humidity	53	0.86	86	Kitchen + 5 additional rooms with high levels of humidity	53	0.84	88
Kitchen + 6 additional rooms with high levels of humidity	61	1.07	85	Kitchen + 6 additional rooms with high levels of humidity	61	0.98	87
Kitchen + 7 additional rooms with high levels of humidity	69	1.26	85	Kitchen + 7 additional rooms with high levels of humidity	69	1.16	87

Point	Power [W]				
	VUT 160 V EC VUT 160 VB EC VUT 160 V1 EC VUT 160 V1B EC VUE 160 V EC VUE 160 VB EC VUE 160 V1 EC VUE 160 V1B EC	VUT 250 VB EC L/R VUE 250 VB EC L/R	VUT 350 V1B EC VUE 350 V1B EC	VUT 350 VB EC VUE 350 VB EC	VUT 550 VB EC VUE 550 VB EC
1	57	180	168	177	337
2	56	179	166	175	337
3	54	168	162	170	337
4	28	63	65	71	118
5	27	57	64	71	113
6	26	52	62	69	107
7	14	15	18	21	34
8	13	15	17	21	66
9	13	14	17	21	32

Point	Sound pressure level at 3 m distance [dBA]				
	VUT 160 V EC VUT 160 VB EC VUT 160 V1 EC VUT 160 V1B EC VUE 160 V EC VUE 160 VB EC VUE 160 V1 EC VUE 160 V1B EC	VUT 250 VB EC L/R VUE 250 VB EC L/R	VUT 350 V1B EC VUE 350 V1B EC	VUT 350 VB EC VUE 350 VB EC	VUT 550 VB EC VUE 550 VB EC
1	24 (34)	35 (45)	28 (38)	28 (38)	26 (36)
2	23 (33)	35 (45)	27 (37)	27 (37)	26 (36)
3	23 (33)	35 (45)	27 (37)	27 (37)	25 (35)
4	20 (30)	24 (34)	23 (33)	23 (33)	24 (34)
5	20 (30)	24 (34)	22 (32)	22 (32)	24 (34)
6	20 (30)	23 (33)	22 (32)	22 (32)	22 (32)
7	13 (23)	18 (27)	15 (25)	15 (25)	15 (25)
8	13 (23)	17 (27)	14 (24)	14 (24)	14 (24)
9	13 (23)	17 (27)	14 (24)	14 (24)	13 (23)

Application options

Ventilation hood



Ceiling connector with a disk valve

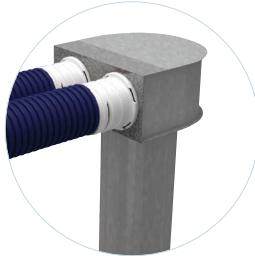

Isovent 150 insulated air duct

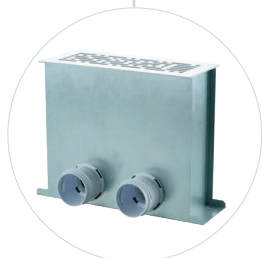
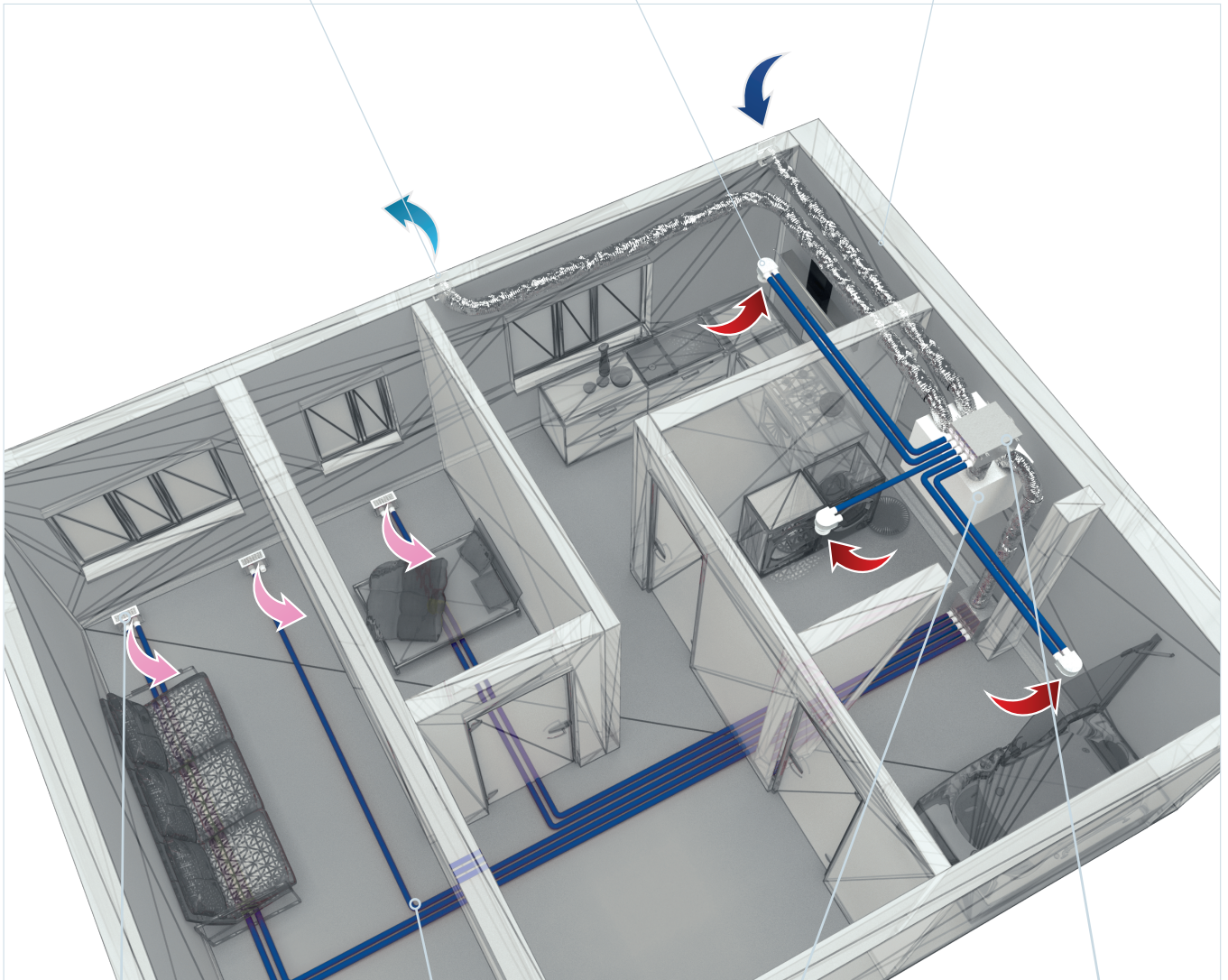

Floor plenum with a grille

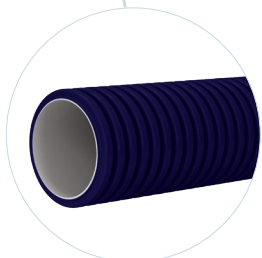

FlexiVent air duct





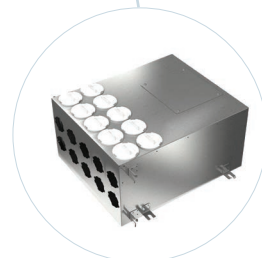





Air handling unit



Collector

## AIR HANDLING UNITS WITH HEAT RECOVERY

### Accessories for air handling units

Model	G4 panel filter		F7 panel filter		LCD control panel	Control panel	Control panel with Wi-Fi	Indoor humidity sensor	CO <sub>2</sub> sensor with indication	CO <sub>2</sub> sensor	Humidity sensor
											
VUT 160 V EC A14			-	-	-						
VUE 160 V EC A14			-	-	-						
VUT 160 VB EC A21			A25	A22	A22 Wi-Fi						
VUT 160 VB EC A14			-	-	-						
VUE 160 VB EC A21			A25	A22	A22 Wi-Fi						
VUE 160 VB EC A14	SF 285x195x10 G4	SF 285x195x10 F7	-	-	-						
VUT 160 V1 EC A14			-	-	-						
VUE 160 V1 EC A14			-	-	-						
VUT 160 V1B EC A21			A25	A22	A22 Wi-Fi						
VUT 160 V1B EC A14			-	-	-						
VUE 160 V1B EC A21			A25	A22	A22 Wi-Fi						
VUE 160 V1B EC A14			-	-	-						
VUT 250 VB EC A21			A25	A22	A22 Wi-Fi						
VUT 250 VB EC A14	SF 340x170x48 G4	SF 340x170x48 F7	-	-	-						
VUE 250 VB EC A21			A25	A22	A22 Wi-Fi	HV2	CO2-1	CO2-2	HR-S		
VUE 250 VB EC A14			-	-	-						
VUT 350 V1B EC A21			A25	A22	A22 Wi-Fi						
VUT 350 V1B EC A14	SF 384x196x40 G4	SF 384x196x40 F7	-	-	-						
VUE 350 V1B EC A21			A25	A22	A22 Wi-Fi						
VUE 350 V1B EC A14			-	-	-						
VUT 350 VB EC A21			A25	A22	A22 Wi-Fi						
VUT 350 VB EC A14	SF 500x196x40 G4	SF 500x196x40 F7	-	-	-						
VUE 350 VB EC A21			A25	A22	A22 Wi-Fi						
VUE 350 VB EC A14			-	-	-						
VUT 550 VB EC A21			A25	A22	A22 Wi-Fi						
VUT 550 VB EC A14	SF 630x198x40 G4	SF 630x198x40 F7	-	-	-						
VUE 550 VB EC A21			A25	A22	A22 Wi-Fi						
VUE 550 VB EC A14			-	-	-						



Model	VOC sensor (0-10 V)	CO <sub>2</sub> sensor (0-10 V)	Humidity sensor (0-10 V)	Kitchen hood	Electric preheater	Electric reheater	Hydraulic U-trap	Air damper	Electric actuator	Summer block	
VUT 160 V EC A14	-	-	-	KH-1	-	-	SH-32	KRV 125			
VUE 160 V EC A14	-	-	-		-	-	-				VL C6 366/285
VUT 160 VB EC A21	DPWQ30600	DPWQ40200	DPWC11200		NKP-125 A21 V.2	NKD-125 A21 V.2	SH-32				
VUT 160 VB EC A14	-	-	-		-	-	-				
VUE 160 VB EC A21	DPWQ30600	DPWQ40200	DPWC11200		NKP-125 A21 V.2	NKD-125 A21 V.2	-				
VUE 160 VB EC A14	-	-	-		-	-	-				
VUT 160 V1 EC A14	-	-	-		-	-	SH-32				
VUE 160 V1 EC A14	-	-	-		-	-	-				VL C6 366/285
VUT 160 V1B EC A21	DPWQ30600	DPWQ40200	DPWC11200		NKP-125 A21 V.2	NKD-125 A21 V.2	SH-32				
VUT 160 V1B EC A14	-	-	-		-	-	-				
VUE 160 V1B EC A21	DPWQ30600	DPWQ40200	DPWC11200		NKP-125 A21 V.2	NKD-125 A21 V.2	-				
VUE 160 V1B EC A14	-	-	-		-	-	-				
VUT 250 VB EC A21	DPWQ30600	DPWQ40200	DPWC11200	-	NKD-160 A21 V.2	SH-32	KRV 160				
VUT 250 VB EC A14	-	-	-	-	-	-					
VUE 250 VB EC A21	DPWQ30600	DPWQ40200	DPWC11200	-	NKD-160 A21 V.2	-					
VUE 250 VB EC A14	-	-	-	-	-	-					
VUT 350 V1B EC A21	DPWQ30600	DPWQ40200	DPWC11200	NKP-160 A21 V.2	NKD-160 A21 V.2	SH-32					
VUT 350 V1B EC A14	-	-	-	-	-	-					
VUE 350 V1B EC A21	DPWQ30600	DPWQ40200	DPWC11200	NKP-160 A21 V.2	NKD-160 A21 V.2	-					
VUE 350 V1B EC A14	-	-	-	-	-	-					
VUT 350 VB EC A21	DPWQ30600	DPWQ40200	DPWC11200	NKP-160 A21 V.2	NKD-160 A21 V.2	SH-32					
VUT 350 VB EC A14	-	-	-	-	-	-					
VUE 350 VB EC A21	DPWQ30600	DPWQ40200	DPWC11200	NKP-160 A21 V.2	NKD-160 A21 V.2	-					
VUE 350 VB EC A14	-	-	-	-	-	-					
VUT 550 VB EC A21	DPWQ30600	DPWQ40200	DPWC11200	NKP-200 A21 V.2	NKD-200 A21 V.2	SH-32	KRV 200				
VUT 550 VB EC A14	-	-	-	-	-	-					
VUE 550 VB EC A21	DPWQ30600	DPWQ40200	DPWC11200	NKP-200 A21 V.2	NKD-200 A21 V.2	-					
VUE 550 VB EC A14	-	-	-	-	-	-					