

Fire protection pressure control valve



■ Application

KRDP excess pressure valves are used to regulate pressure difference in fire protection ventilation systems meeting the requirements of DSTU EN 12101-6:2015 "Smoke protection systems. Part 6. Technical requirements for pressure difference systems" (EN 12101-6:2005, IDT; EN 12101-6:2005/AC:2006, IDT).

When calculating air pressure systems the air leakage through open doors, openings and other leaks are taken into account. When these are closed, the pressure difference between the protected volumetric space (airlock vestibules, smokeproof stairwells, elevator halls, etc.) and the fire occurrence zone (corridors, halls, lobbies, etc.) can reach critical values.

In order to regulate the pressure difference in the above volumetric spaces and to allow the doors to open freely on the escape route (rated force 100 N), a KRDP valve must be used.

The device functions both as:

- an excess pressure control valve that automatically opens when a pressure difference occurs;
- a fire-protection, flame-retarding valve that prevents flue gases from entering the protected volumetric spaces.

■ Design

The valve is made in a rectangular cross-section of galvanised steel (general industrial version) or stainless steel (corrosion-resistant version), depending on the requirements.

The device consists of one or more fire-resistant rotary type blades characterised by a low thermal conductivity coefficient.

A spring mechanism mounted directly in the valve body acts as an adjustment element.

The product is available with two flanges for direct connection to air ducts or with a single flange for installation in a wall.

The valve can only be mounted in a vertical position and all the axes of the working plates (blades) must be parallel to the floor, and the adjusting element located outside the plates movement trajectory.

Fire resistance class – EI 120.

The pressure control range is 20-150 Pa.

KRDP valve can be used in temperate and cold climates.

Designation key

KRDP-WxH/120-...

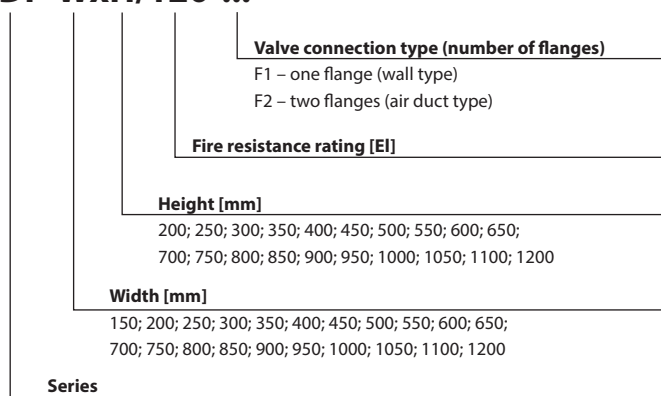

■ Connection and overall dimensions of the standard range of valves

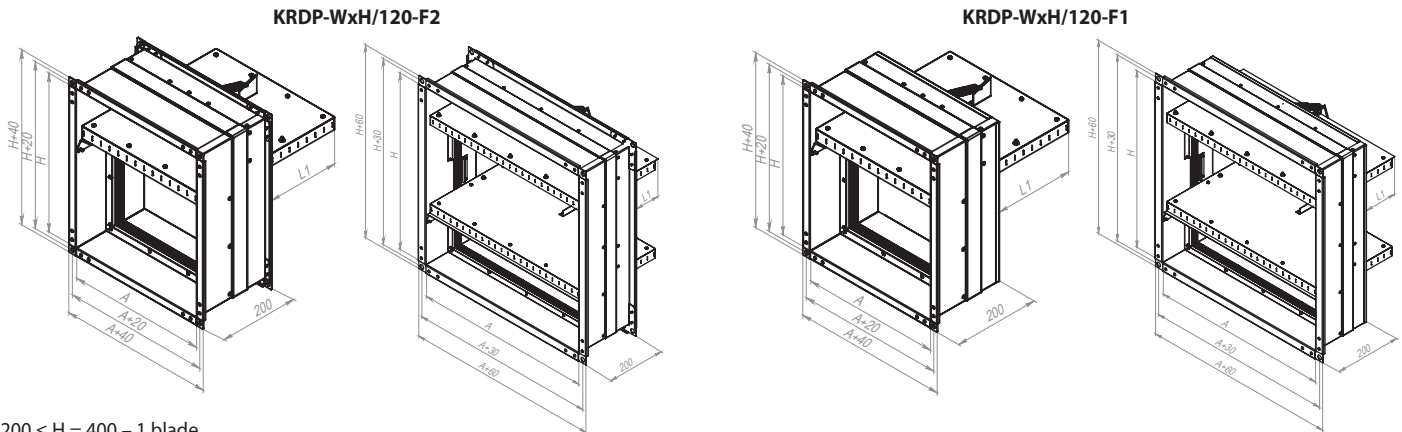

200 ≤ H = 400 – 1 blade
 400 < H = 800 – 2 blades
 800 < H – 3 blades

Blade overhang size beyond the body dimension

$$L1 = H/n - 150$$

H – height of the valve [mm]
 n – number of blades

■ Standard size range of KRDP valves, minimum cross-sectional area [m²]

H W	200	250	300	350	400	450	500	550	600	650	700	750	800	850	900	950	1000
200	0.034	0.044	0.054	0.064	0.074	0.078	0.088	0.098	0.108	0.118	0.128	0.138	0.148	0.152	0.162	0.172	0.182
250	0.0425	0.055	0.0675	0.08	0.0925	0.0975	0.11	0.1225	0.135	0.1475	0.16	0.1725	0.185	0.19	0.2025	0.215	0.2275
300	0.051	0.066	0.081	0.096	0.111	0.117	0.132	0.147	0.162	0.177	0.192	0.207	0.222	0.228	0.243	0.258	0.273
350	0.0595	0.077	0.0945	0.112	0.1295	0.1365	0.154	0.1715	0.189	0.2065	0.224	0.2415	0.259	0.266	0.2835	0.301	0.3185
400	0.068	0.088	0.108	0.128	0.148	0.156	0.176	0.196	0.216	0.236	0.256	0.276	0.296	0.304	0.324	0.344	0.364
450	0.0765	0.099	0.1215	0.144	0.1665	0.1755	0.198	0.2205	0.243	0.2655	0.288	0.3105	0.333	0.342	0.3645	0.387	0.4095
500	0.085	0.11	0.135	0.16	0.185	0.195	0.22	0.245	0.27	0.295	0.32	0.345	0.37	0.38	0.405	0.43	0.455
550	0.0935	0.121	0.1485	0.176	0.2035	0.2145	0.242	0.2695	0.297	0.3245	0.352	0.3795	0.407	0.418	0.4455	0.473	0.5005
600	0.102	0.132	0.162	0.192	0.222	0.234	0.264	0.294	0.324	0.354	0.384	0.414	0.444	0.456	0.486	0.516	0.546
650	0.1105	0.143	0.1755	0.208	0.2405	0.2535	0.286	0.3185	0.351	0.3835	0.416	0.4485	0.481	0.494	0.5265	0.559	0.5915
700	0.119	0.154	0.189	0.224	0.259	0.273	0.308	0.343	0.378	0.413	0.448	0.483	0.518	0.532	0.567	0.602	0.637
750	0.1275	0.165	0.2025	0.24	0.2775	0.2925	0.33	0.3675	0.405	0.4425	0.48	0.5175	0.555	0.57	0.6075	0.645	0.6825
800	0.136	0.176	0.216	0.256	0.296	0.312	0.352	0.392	0.432	0.472	0.512	0.552	0.592	0.608	0.648	0.688	0.728
850	0.1445	0.187	0.2295	0.272	0.3145	0.3315	0.374	0.4165	0.459	0.5015	0.544	0.5865	0.629	0.646	0.6885	0.731	0.7735
900	0.153	0.198	0.243	0.288	0.333	0.351	0.396	0.441	0.486	0.531	0.576	0.621	0.666	0.684	0.729	0.774	0.819
950	0.1615	0.209	0.2565	0.304	0.3515	0.3705	0.418	0.4655	0.513	0.5605	0.608	0.6555	0.703	0.722	0.7695	0.817	0.8645
1000	0.17	0.22	0.27	0.32	0.37	0.39	0.44	0.49	0.54	0.59	0.64	0.69	0.74	0.76	0.81	0.86	0.91

The working cross-sectional area is determined by the following formula:

$$S = k_r \left(\frac{V_D}{\sqrt{\frac{2\Delta P_{kt}}{\rho}}} \right) S_D$$

V_D – air flow velocity in the open doors opening when the valve closed [m/s].

S_D – area of the opened doors [m²].

k_r – coefficient taking into account the design features of a KRDP valve. For the KRDP valve, we take the value of 1.7.

ΔP_{kt} – pressure drop at the valve when the doors are closed, which corresponds to the excess pressure in the airlock vestibule [Pa].

ρ – air density [kg/m³].